

# 808. Development of a system to obtain vertical track geometry measuring axle-box accelerations from in-service trains

J. I. Real<sup>1</sup>, L. Montalbán<sup>2</sup>, T. Real<sup>3</sup>, V. Puig<sup>4</sup>

<sup>1,2</sup> Department of Transportation Engineering and Infrastructures, School of Civil Engineering Technical University of Valencia, 14 Camino de Vera, 46022 Valencia, Spain

<sup>3</sup> Department of Construction Engineering, Public Works and Urban Infrastructure, School of Engineering University of Alicante, Campus de Sant Vicent del Raspeig, P. O. Box 99, E-03080 Alicante, Spain

<sup>4</sup> Management Entity of the Transport Network and Ports of the Generalitat Pda. Xirivelleta s/n, 46014 Valencia, Spain

E-mail: <sup>1</sup>jureaheer@tra.upv.es, <sup>2</sup>laumondo@cam.upv.es, <sup>3</sup>teresa.real@ua.es, <sup>4</sup>puig\_vicgar@gva.es

(Received 23 April 2012; accepted 14 May 2012)

**Abstract.** Nowadays, metropolitan railway systems are in great demand, so they offer high-frequency services for the most part of the day. Therefore there are only a few hours available at night to carry out maintenance tasks. This research develops a system that records vertical accelerations undergone by the bogies of in-service railway vehicles. As accelerations are measured during regular services of trains, no additional vehicles or personnel are needed and maintenance planning is optimized. Accelerations are processed to obtain vertical track alignment in order to determine whether the track needs repair. The developed system has been validated by comparing its results to the actual state of the track provided by a track monitoring trolley. Comparison is performed by using both graphical and statistical methods. Real data was obtained from measurements taken on Line 1 of the Alicante tram network (Spain). This paper presents procedure for data collection, its mathematical processing and analysis in order to identify track condition.

**Keywords:** axle-box, accelerometer, maintenance, track monitoring.

## Nomenclature

$c_2$	Primary suspension damping coefficient
$dt$	Sampling time increment
$E_{rail}$	Rail Young's modulus
$H_1$	Transfer function
$k$	Wave number
$k_1$	Vertical track stiffness
$k_2$	Primary suspension stiffness
$k_{\phi 0}$	Cut-off wave number
$L_i$	Filter section gains
$L(k)$	High-pass filter function
$m_1$	Lower mass
$m_2$	Upper mass
$n$	Recorded data length
$P$	Contact force
$P(k)$	Phase correction function
$R_{rail}$	Rail radius
$R_{wheel}$	Wheel radius
$t$	Time
$T$	Period
$v$	Train speed
$x$	UTM $x$ -coordinate

$x_1$	Lower mass displacement
$x_2$	Upper mass displacement
$\dot{x}_i$	Vertical velocity
$\ddot{x}_i$	Vertical acceleration
$X_1^*$	Filtered displacement
$x(t)$	Signal in time domain
$X(\omega)$	Signal in frequency domain
$y$	UTM $x$ -coordinate
$z$	Vertical rail profile
$\varphi$	Phase
$\varphi^*$	Corrected phase
$\lambda$	Defect wavelength
$\nu$	Rail Poisson's coefficient
$\omega$	Frequency

## 1. Introduction

In society the demand for mobility by metropolitan railway transport system is very high. Thereby, urban trains operate at high frequency during almost the whole day. So, the number of hours available to perform maintenance work is very limited. Therefore, there is a necessity for fast and effective maintenance procedures.

Among the different existing maintenance strategies, the optimum one is the so-called predictive maintenance [1]. Predictive techniques are based on the condition determination of in-service equipment in order to predict when maintenance should be performed. This modus operandi prevents unexpected equipment failures and offers cost savings because tasks are carried out only when necessary. Nevertheless, this system presents one inconvenience: a continuous necessity of track monitoring. For this reason, the motivation of this research is to solve that inconvenience developing a monitoring system capable of operating continuously without presenting excessive additional costs or interference in the normal service of trains.

Traditionally, monitoring systems have been based on contact methods [2]. These methods present the inconvenience of producing an elevated wear of both, the measuring system and the rails. Furthermore, they do not allow measuring beyond 150 km/h and they cannot detect rail defects longer than 40 m. Non-contact methods have been developed to correct these handicaps. One of the non-contact techniques is the optical method based on laser systems that scan the rail and register its profile. This is a widely used technique as it provides precise and faster information about track condition. However, laser sensors are expensive and not very robust, so they are inappropriate for the harsh railway environment. Moreover, the measuring principle is based on the mid-chord theory that presents the problem of filtering some wavelength defects so they cannot be detected. Several authors such as Nagamuna et al. [3], Yazawa and Takeshita [4] and Ahmadian [5] have widely studied this phenomenon.

Another non-contact technique is the so-called inertial method focused on determining track geometry by measuring accelerations of the passing vehicle. Two different applications of inertial methods have been developed. On the one hand, special vehicles are used to measure accelerations and other variable. These vehicles are specifically designed for monitoring purposes and require specific devices to measure every track condition parameter. These special vehicles reach a high sophistication level and, consequently, they are very expensive. Furthermore, operations of the inertial vehicle must be scheduled to avoid interference with regular trains or with other maintenance tasks. To solve these schedule conflicts, new approaches are focused on developing inertial systems attaching accelerometers in the axle-box of in-service railway vehicles. Installed sensors are highly resistant and economic. The only handicap of this inertial method is the difficulty of data processing to obtain relevant results.

This research is focused on simplifying data processing in order to obtain information about track condition and geometry from recorded accelerations.

Inertial systems are capable of measuring different track geometry parameters as vertical or lateral alignment, gauge, twist, etc. This paper only studies vertical alignment defects as they are a conditioning factor of derailment risk. Study of other geometry parameters will be the object of future research work. The aim of this article is to design an inertial system to obtain vertical track alignment from axle-box measured accelerations of an in-service train. Accelerations are integrated and post-processed to input them onto a vehicle dynamic model to calculate vertical rail profile. This model is calibrated and validated by comparison with data provided by the traditional track surveying trolley. Input data have been obtained from real measurements carried out on line 1 of Alicante tramway.

## 2. Literature Review

Different research works concerning track monitoring using inertial methods have been carried out. Non-commercial prototypes consisting on axle-box attached accelerometers have been developed to record necessary data. It is essential to study both, the installation aspects and the data manipulation. If data manipulation does not receive the necessary attention, some valuable information may be lost during data processing. Likewise, if accelerometer choice or installations are not carried out carefully, distorted results might be obtained. Some authors focus on the design and characteristics of the instrumented bogie and other deeply study data manipulation.

Boccione et al. [6] investigate the evaluation of short pitch corrugation. They deal with experimental data acquisition problem in depth, but any signal processing or analytical modeling is made. Important conclusions are obtained concerning the best measurement points and the influence of the substructure on the recorded vibration levels. Another research focused on experimental campaign test carried out by Mannara et al. [7]. Their performed feasibility study of the used technology and qualitatively described the recorded accelerations.

Other authors have conducted studies focused on data treatment. There are different methods to analyze acceleration recordings. Yazawa et al. [4] use the mid-chord offset method to solve the distortion of the waveform produced when double integrating accelerations. This method solves the problem of waveform distortion by means of a high-pass filtering process for stabilizing the double integration of accelerations. The main problem is that they need to use laser scanners as well as accelerometers and they cannot be used in regular-service railways. Toliyat et al. [8], in turn, used wavelet decomposition for the detection of rail defects. Acquired signal was decomposed to twelve levels and the amount of energy representing each level was then analyzed.

Coudert et al. [10], compare two different methods for obtaining rail profile: a conventional filtering process by means of a band-pass filter and a wavelet analysis. Conclusions are that the band-pass filter is appropriate to determine the specific types of defects and select the ideal maintenance work. On the other hand, wavelet decomposition becomes useful to precisely locate the defects along the railway track.

Rail defects appear in a wide range of wavelengths. Grassie [9] classified the different track irregularities according to their wavelength and their respective excited frequencies. Short wavelength defects are known as corrugation and long wavelength ones are called geometry track defects. This paper is focused on long wavelength defects as they excite dynamic behavior of the vehicle.

A practically complete research that deals with both experimental setup and data processing was performed by Weston et al. [11]. Used sensors are a bogie-mounted pitch-rate gyro to obtain mean vertical alignment and axle-box accelerometers to calculate the defects wavelength. Accelerations are double integrated and a high-pass filter with zero phase shifts is applied. Another interesting work was done by Mori et al. [12]. They sophisticated the data manipulation

process and developed nearly real-time condition monitoring system based on the axle-box acceleration of Shinkansen underground vehicles.

Current research started with the development of data manipulation process. A vehicle model was stated by Real et al. [13] and equations of motion were solved in the frequency domain. Real data were provided from a special vehicle called ‘VAI’ (installations monitoring vehicle) running along line 9 of Madrid underground. Research has been extended and this paper presents important improvements. On the one hand, an inertial setup to measure acceleration of in-service vehicles has been designed, so no special vehicles are needed. On the other hand, data processing has been modified to be adapted to the new data collection procedure. Furthermore, comparison between inertial methods and traditional methods has been carried out both graphically and statistically.

### 3. Methodology

This research is organized in three parts. First of all, data acquisition setup is described. As mentioned, two data measurements are carried out: by means of the designed inertial system and using the track surveying trolley. Characteristics of used sensors are described and mounting procedure is explained. Secondly, mathematical background for obtaining vertical track geometry from recorded accelerations is provided. Finally, obtained results are analyzed and conclusions are stated. Data analysis is made in three steps: accelerations are processed using the explained mathematical model. Then, a double comparison (graphical and statistical) with data from the track surveying trolley is made, so obtained results are validated. As a final point, track condition is analyzed and detected defects are studied both in magnitude and in their associated wavelength.

As commented before, this research only studies vertical track defects. Spanish standards -N. R. V. 7-3-5.5 [14] - establish two kinds of vertical alignment defects. ‘Differences’ are defined as the existing discrepancy between the theoretical rail elevation and its actual value. ‘Variations’, in turn, are defined as the value of the difference between successive measured elevations every three meters. Table 1 shows the maximum allowed values in mm for vertical alignment defects.

**Table 1.** Tolerances for vertical track geometry. N. R. V. 7-3-5.5 RENFE

	Speed < 120 km/h	Speed ≥ 120 km/h
Differences	±25 mm	±25 mm
Variations	8 mm	6 mm

### 4. Experimental measurements

Data collection has been carried out in two different ways in order to compare the results and validate the developed inertial model. First, axle-box vertical accelerations have been recorded by the installed accelerometers at the vehicle. Afterwards, track monitoring trolley has been used to measure the actual state of both rails. These two experimental procedures have been carried out along the same stretch of track during the same day to allow perfect data matching. Data comes from Line 1 of Alicante tram, specifically from the stretch between the Mileposts 37+642 and 40+038, corresponding to Hospital Vila and Hiper Finestrat stations. Description of both measurement methods is detailed below.

Four accelerometers have been installed on the lead bogie axle-boxes of the railway vehicle. The tram in-service on the Line 1 is a VÖSSLOH-4100 with maximum speed of 100 km/h. The chosen piezo-accelerometers (PCB 354C02) present a good sensitivity (10 mV/g) and measure triaxial accelerations in a frequency range of 0.5-20 kHz and 500g full scale. Accelerometers have been fixed to the bogie by means of magnetic bases to avoid surface drilling (Fig. 1). Data

acquisition system (SARP MK2) used for recording accelerations is placed inside the train cockpit. This acquisition system permits synchronization of every recorded parameter.

Wires connecting accelerometers to data acquisition system go from bogies to the cockpit, so they need to be protected to prevent them from breaking due to the relative car-to-bogie displacement that takes place at the curves. A GPS (Garmin 18x-5 Hz) is also needed to locate the train along the track and to calculate its travelling speed. Table 1 in the appendix shows further details of used sensors.

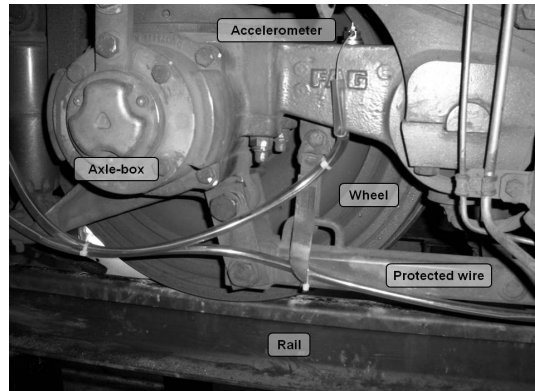

**Fig. 1.** Instrumented bogie

Sampling frequency is set to be 100 Hz so Nyquist criterion is satisfied [15]. As maximum line speed is 100 km/h, accelerations are discretely recorded every 15 cm or at smaller distance, depending on the travel speed. Measured data are extracted from the 13 recording channels (3 channels for each of the installed accelerometers corresponding to the three axes; and 1 channel for the GPS signal). Although acceleration is measured in the three axes (longitudinal, transversal and vertical), only vertical recordings are analyzed. Transversal acceleration analysis will be object of a future research concerning to lateral alignment calculation. Figure 2 shows orientation of accelerometer axes.



**Fig. 2.** Detail of bogie mounted accelerometer with oriented axes

On the other hand, actual vertical track profile has been obtained using the GRP SYSTEM FX AMBERG track monitoring trolley (Fig. 3). This trolley is a manually driven device capable of measuring various track parameters providing an instant record of track conditions and geometry. A total station is used to assign UTM coordinates of each measured point for both rails. A robotic total station (Leica TRP) that automatically follows the trolley prism has been used. Total station position has been calculated by inverse intersection to three points. UTM coordinates of these three points are known because they are part of a topographic net used during the tramway line construction.



**Fig. 3.** Track surveying trolley at Hiper Finestrat station

In summary, recorded signal by the inertial system consists of four vertical accelerations as a function of time measured every 0.01 s. GPS signal provides geographic coordinates (latitude, longitude and altitude) every 0.2 s. Due to this sampling interval discrepancy, GPS signal must be re-sampled. In this way, geographic coordinates are obtained every 0.01 s using linear interpolation. Furthermore, it is necessary to obtain UTM coordinates to allow comparison with data provided by track surveying trolley. As GPS systems provide coordinates in the datum WGS-84 and wanted system is ED-50, a series of transformations has to be carried out. This is achieved by programming a spreadsheet with the corresponding formulae available in different topography and geodesy literature as García-Tejero [16]. Once UTM coordinates in the ED-50 system are obtained, speed of the train is obtained as follows:

$$v_i = \frac{\sqrt{(x_i - x_{i-1})^2 + (y_i - y_{i-1})^2}}{dt} \quad (1)$$

where  $x$  and  $y$  are the UTM coordinates,  $v$  is the estimated train speed and  $dt$  is equal to 0.01 s. Once this signal pre-treatment is done, inertial system data are introduced as an input to the model described in next section.

### 5. Mathematical model

This section describes model equations and transformations needed to obtain vertical track alignment as a function of the Milepost from recorded vertical accelerations as a function of time. Mathematical procedure consists of a series of steps which transform original data to obtain desired data. First step is double integration of the signal to get vertical displacements of the accelerometer. Then, it is necessary to filter the integrated accelerations to eliminate undesired frequencies and correct distorted phases. Afterwards, equations of motion of the vehicle model are solved to obtain vertical position of the rails from vertical filtered displacement of the accelerometers. Finally, data is reverted into the time domain and then transformed into the space domain to locate the defects along the track. Figure 4 shows a scheme of the transformation procedure. All steps are described below.



**Fig. 4.** Data processing diagram

## 5. 1 Integration of accelerations

Double integration is applied to recorded signal to obtain vertical displacements from measured accelerations. Since accelerations are a series of discrete recordings, numerical integration must be used. Trapezoidal rule of integration [17] has been implemented. Although numerical integration process seems to be straightforward, some difficulties must be corrected to avoid final results distortion. These difficulties are a reduction of high-frequency contents of the waveform, an amplification of low frequencies and a signal phase shift.

There are different methods used to improve velocity and displacement calculated diagrams. A widely used technique is the so-called ‘baseline correction’. This procedure consists of defining a baseline function that fits the data of the diagram by least squares method. Initial condition - zero velocity at initial instant - must be satisfied. Corrected velocities are obtained by difference between original velocity diagram and its corresponding baseline. This method is applied in seismic engineering when integrating accelerogram charts from an earthquake [18]. Next figure graphically shows baseline correction procedure. Chosen baseline function is a sixth degree polynomial.

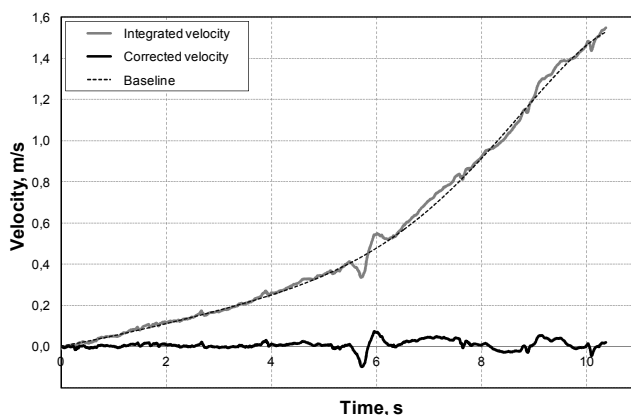

Fig. 5. Baseline correction in numerical integration

## 5. 2 Displacements filtering

Once integrated velocity has been corrected, the process is repeated for integrated displacements. When corrected displacements have been calculated, next step is displacement filtering for elimination of undesired frequencies. As filtering is carried out in frequency domain, it is necessary to convert data from time domain to frequency domain. This domain transformation is performed by means of discrete Fourier transform, which has the expression:

$$X(\omega) = \sum_{r=1}^n x(t) e^{2\pi i(r-1)(s-1)/n} \quad (2)$$

where  $X(\omega)$  is the frequency domain signal,  $x(t)$  is the time domain signal,  $i$  is the imaginary unit,  $n$  is the data length and  $r$  and  $s$  are indexes varying from 1 to  $n$ . Time domain goes from  $t_0 = 0$  to  $t_n = T$ , being the separated values for  $t$  calculated as  $t_r = \Delta t(r-1)$ , where  $T$  is the sample time length and  $\Delta t$  the time increment used when sampling, i.e. 0.01 s. Frequency domain, in turn, varies from  $\omega_0$  to  $\omega_n$  taking the values:

$$\omega_s = \frac{2\pi}{T}(s-1). \quad (3)$$

Corresponding wavelengths are obtained as  $\lambda_r = vt_r$  where  $v$  is the calculated train speed using (1). All these formulae can also be written in the wave number ( $k$ ) domain by means of the variable change  $\omega = vk$ . Once signal is obtained in the frequency domain, filter function can be applied. A high-pass filter and a phase correction function are used to correct, respectively, the amplitude of the waveform and the signal phase shift mentioned in preceding section.

The used high-pass filter is expressed in terms of wave number and is defined by the function:

$$L(k) = \begin{cases} 0 & \text{if } |k| < k_A \\ L_1 & \text{if } k_A \leq |k| < k_B \\ \frac{L_2 - L_1}{k_C - k_B} (k - k_B) + L_1 & \text{if } k_B \leq |k| < k_C \\ L_2 & \text{if } k_C \leq |k| < k_D \\ \frac{L_3 - L_2}{k_E - k_D} (k - k_D) + L_2 & \text{if } k_D \leq |k| < k_E \\ L_3 & \text{if } k_E \leq |k| \end{cases} \quad (4)$$

where  $L(k)$  defines the high-pass filter function;  $k_A, k_B, k_C, k_D$  and  $k_E$  are the wave numbers that define the different filter sections and  $L_1, L_2$  and  $L_3$  are the gains of each filter section. Next figure shows a plot of the filter function.

Phase correction function is defined by:

$$P(k) = \begin{cases} e^{i(ak-b-\phi)} & \text{if } k < -k_{\phi 0} \\ 1 & \text{if } -k_{\phi 0} \leq k \leq k_{\phi 0} \\ e^{i(ak+b-\phi)} & \text{if } k > k_{\phi 0} \end{cases} \quad (5)$$

where  $P(k)$  is the phase correction function,  $k_{\phi 0}$  is the cut-off wave number,  $\phi$  is the respective phase associated to each  $X(k)$  and  $a$  and  $b$  are the parameters to be adjusted. This function leaves phases corresponding to  $X(k)$  when  $-k_{\phi 0} \leq k \leq k_{\phi 0}$  unaltered. Instead, for wave numbers out of that interval, phase changes according to a straight line following the equation  $\phi^*(k) = ak \pm b$ , where  $\phi^*(k)$  is the corrected phase.

Next step consists on selecting parameters values for both, the filter function and the phase correction function. Parameters to be adjusted are  $k_A, k_B, k_C, k_D, k_E, L_1, L_2, L_3, k_{\phi 0}, a$  and  $b$ . To obtain their values, an iterative process has been carried out. A 156.5 m length stretch of the analyzed track has been selected. For this stretch, parameter values are calculated with the condition of vertical rail profile matching between data from accelerometers and data from track surveying trolley. This iterative procedure used to obtain optimum parameter values is called model calibration. Once these values are found, a comparison between both data series is made along the complete analyzed track. If this comparison is successful, adjusted parameters are accepted and the model is validated. Calibration and validation is separately calculated for both rails and obtained values are provided in Table 2.

When all these values have been set, filtered and phase corrected displacements are obtained in the wave number domain as follows:

$$X_1^*(k) = X_1(k) \cdot L(k) \cdot P(k). \quad (6)$$



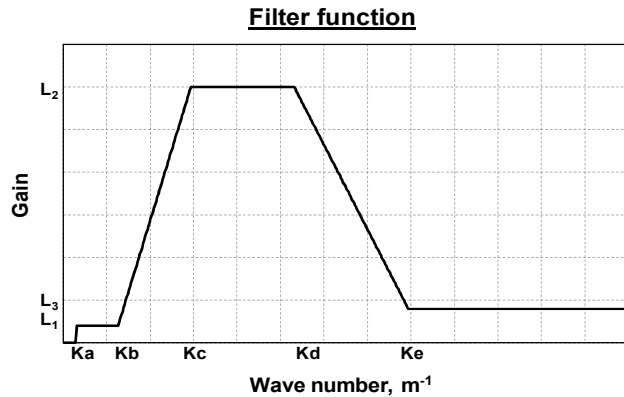

Fig. 6. Used high-pass filter function

Table 2. Values of parameters for filter and phase correction functions

Parameter	Right rail	Left rail
$k_A$ (rad/m)	0.040	0.040
$k_B$ (rad/m)	0.042	0.042
$k_C$ (rad/m)	0.063	0.063
$k_D$ (rad/m)	0.251	0.251
$k_E$ (rad/m)	0.628	0.419
$L_1$	1.000	1.000
$L_2$	1.300	0.700
$L_3$	0.200	0.500
$a$ (m)	0.248	0.300
$b$ (rad)	1.347	1.800
$k_{\theta 0}$ (rad/m)	2.271	0.251

And obtained displacements are returned back to the frequency domain by means of the variable change  $\omega = \nu k$ .

### 5. 3 Equations of motion

After filtering, vertical displacement of accelerometers has been obtained. To calculate vertical displacement of the railhead, a model must be used. This model takes into account the significant elements of the vehicle, the stiffness of the track platform and the wheel-rail contact interaction. A widely used model in railway vibrations engineering is the so-called ‘quarter of bogie’ model, with two degrees of freedom. This model (Fig. 7) was proposed by Melis [19], and considers the train as two masses connected by a spring ( $k_2$ ) and a damper ( $c_2$ ) representing the primary suspension. Upper mass ( $m_2$ ) represents a quarter of the mass of a bogie frame and the train housing. Lower mass ( $m_1$ ), in turn, simulates half of an axle mass. Lower and upper mass undergo vertical displacements  $x_1$  and  $x_2$  respectively. Function to be obtained is  $z$ , the vertical rail profile.

The parameter  $k_1$  represents vertical stiffness of the track, including the effect of the rail, the sleeper, the ballast, the subgrade and the Hertz contact between wheel and rail according to the formulation:

$$k_1 = \frac{1}{\frac{1}{k_{Hertz}} + \frac{1}{k_{rail}} + \frac{1}{k_{sleeper}} + \frac{1}{k_{ballast}} + \frac{1}{k_{subgrade}}}. \quad (7)$$

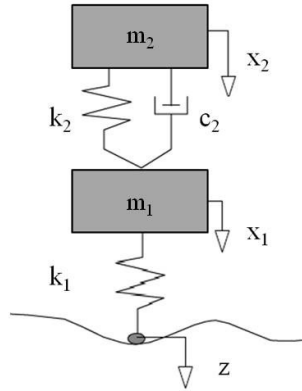

Fig. 7. Quarter of bogie model

Different stiffness values have been estimated from recommendations stated at reference [19]. Hertz contact stiffness is obtained according to Grassie formulation (8), where  $R_{wheel}$  and  $R_{rail}$  are wheel and rail radiuses respectively,  $E_{rail}$  is the Young's modulus of steel,  $\nu$  is steel Poisson's coefficient and  $P$  represents applied force in the contact:

$$k_{Hertz} = \sqrt[3]{\frac{6E_{rail}P\sqrt{R_{wheel} - R_{rail}}}{4(1-\nu)^2}} \quad (8)$$

With all these considerations, model parameters have been estimated. Data referring to the masses and suspensions have been provided by the Alicante tram network operating company FGV (Generalitat Valenciana Railways). All the values from the model are listed in Table 3.

Table 3. Values of model parameters

Model parameters	
$m_1$ (kg)	130
$m_2$ (kg)	8362.5
$k_1$ (N/m)	$1.55 \cdot 10^7$
$k_2$ (N/m)	$4.5 \cdot 10^5$
$c_2$ (N/ms <sup>-1</sup> )	30000

Equations of motion of the quarter-of-bogie model in the time domain are stated below:

$$\begin{aligned} m_2 \ddot{x}_2 + c_2(\dot{x}_2 - \dot{x}_1) + k_2(x_2 - x_1) &= 0 \\ m_1 \ddot{x}_1 - c_2 \dot{x}_2 + c_2 \dot{x}_1 - k_2 x_2 + (k_1 + k_2)x_1 - k_1 z &= 0 \end{aligned} \quad (9)$$

where  $x_i$  is the vertical displacement of the  $i$ th mass,  $\dot{x}_i$  represents the first derivative with respect to time, i.e. vertical velocity, and  $\ddot{x}_i$  is the second derivative with respect to time, i.e. vertical acceleration. As input functions are expressed in frequency domain, equations need to be transformed into this domain by means of Fourier transform. Equations of motion in frequency domain are:

$$\begin{aligned} -m_2 \omega^2 X_2 + ic_2 \omega(X_2 - X_1) + k_2(X_2 - X_1) &= 0 \\ -m_1 \omega^2 X_1 - ic_2 \omega X_2 + ic_2 \omega X_1 - k_2 X_2 + (k_1 + k_2)X_1 - k_1 Z &= 0 \end{aligned} \quad (10)$$

Solving the system for  $Z(\omega)$ , solution can be expressed by means of the convolution product of the transfer function  $H_1(\omega)$  times the displacements of the lower mass as follows:

$$Z(\omega) = H_1(\omega) \cdot X_1^*(\omega) \quad (11)$$

Transfer function  $H_1(\omega)$  has the following expression:

$$H_1(\omega) = \frac{-\omega^4 m_1 m_2 - i\omega^3 c_2 (m_1 + m_2) + \omega^2 (m_1 k_2 + m_2 (k_1 + k_2)) + i\omega c_2 k_1 - k_1 k_2}{\omega^2 k_1 m_2 + i\omega k_1 c_2 - k_1 k_2} \quad (12)$$

Once  $Z(\omega)$  is obtained, vertical rail profile must be returned to time domain by using inverse Fourier transform for discrete functions as follows:

$$z(t) = \frac{1}{n} \sum_{r=1}^n Z(\omega) e^{-2\pi i(r-1)(s-1)/n} \quad (13)$$

Finally, as the aim of this research is to locate the defects at a specific position along the track, it is necessary to obtain vertical track profile as a function of the Milepost. This is done by using GPS records and knowing a Milepost of a specific section of the track. In this case, Milepost and UTM coordinates of Hiper Finestrat station have been provided.

## 6. Analysis of results

In this section, a comparison between calculated and actual vertical profile is made. To compare both series, graphical and statistical comparisons have been carried out. Once comparison has been made successfully and inertial system is validated, analysis of vertical defects existing on the measured track stretch has been performed. Graphical comparison is shown in the chart below (see Fig. 8).

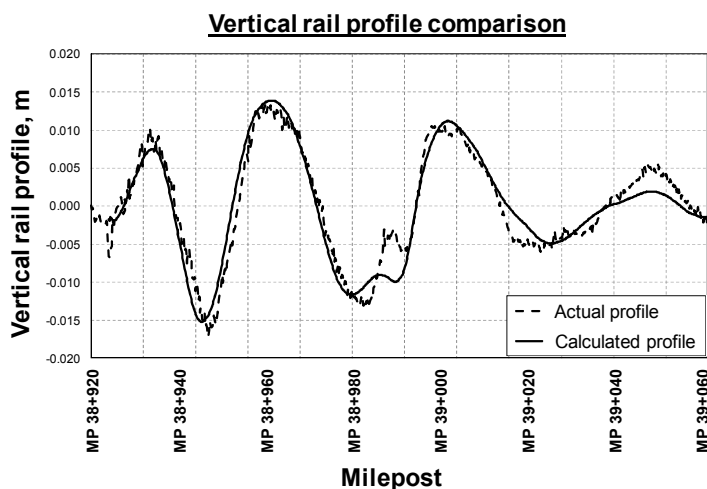

Fig. 8. Graphical comparison of vertical rail profile obtained by inertial methods and the track surveying trolley

Statistical comparison of both series has been performed by using the Student's  $t$ -test. Null hypothesis is done and it states that the means of both series (real and calculated) are equal. It

has been verified that both series are normally distributed populations and their variances are assumed to be equal. *T*-test is performed and results show that the mean of both series can be considered to be equal with a *p*-value 0.9992. Further details about *t*-test can be found in references [20] and [21].

Last step of this research is the evaluation of track conditions. Then, defects are located according to their definition (Table 1). Next graph indicates stretches with and without defects. It is noticed that defects calculated by inertial method and by track surveying trolley appear overlapped, which means that the designed inertial system provides high-quality results. Discrepancy between both series has a maximum value of 6 meters in a total analyzed length of 1500 m. Therefore, committed error is equal to 0.4 %, which is an admissible value. In conclusion, designed inertial system provides good results about vertical track geometry, locating the defects with an error less than 1 %.

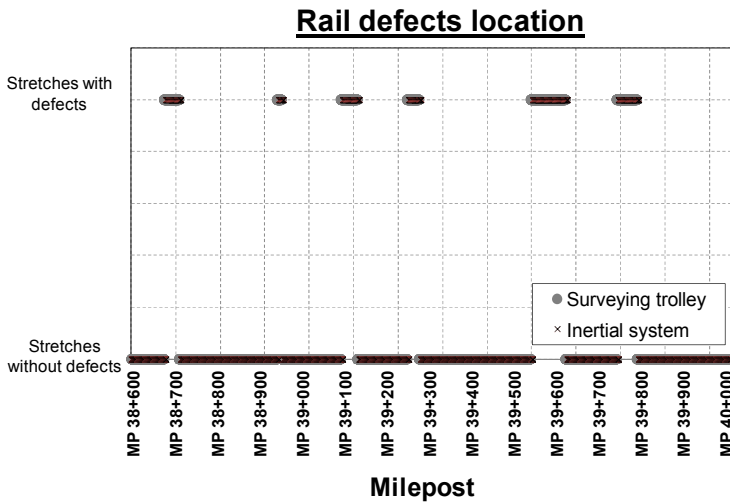

Fig. 9. Evaluation of track condition attending to vertical defects

Main purpose of the research has been successfully achieved. Nevertheless, it is of interest to deeply analyze obtained data. Therefore, spectral density of vertical alignment defects is studied by plotting the spectral density graph, which depicts squared wave amplitude versus associated wavelength. To obtain this plot, data coming from Fourier transform are used. Amplitude and wavelength are calculated as follows:

$$A_k = \sqrt{a_k^2 + b_k^2} \tag{14}$$

$$\lambda_k = \frac{2\pi}{\omega_k} \tag{15}$$

where  $A_k$  is the amplitude associated with each wavelength  $\lambda_k$ , the coefficients  $a_k$  and  $b_k$  correspond to the real part and the imaginary part of  $X(\omega)$  and  $k$  varies from 1 to  $n$ .

According to the European standard (UNE-EN 13848-1 [22]), vertical alignment wavelengths are classified in three different groups. Short-wave defects present a wavelength included in the range of 3-25 m. Medium-wave defects are comprised between 25 m and 70 m. Long-wave defects, in turn, have wavelengths from 70 m to 150 m. Fig. 10 shows that predominant defects observed in the analyzed track have wavelengths from 30 m to 50 m, so they are classified as medium-wave defects.

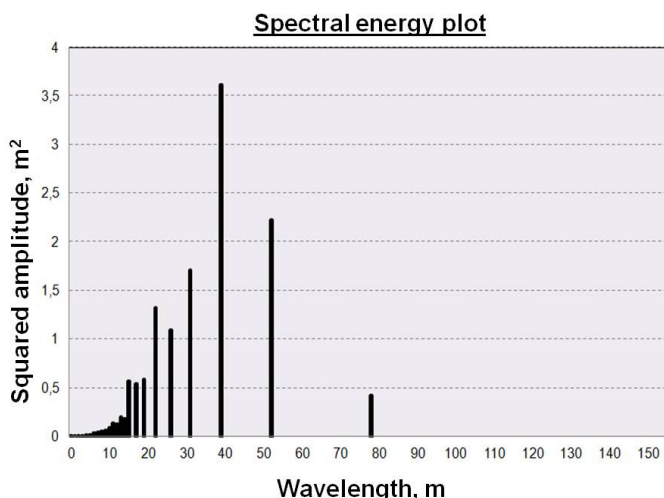

Fig. 10. Spectral energy plot

## 7. Conclusions and further research

This research has developed an inertial system capable of obtaining vertical track geometry from recorded accelerations and locating defects along the track with an error less than 1 % compared to traditional methods. This inertial system can be used as a tool for track condition monitoring in predictive maintenance.

It is possible to improve both, installation system and data processing. Installation can be sophisticated without the presence of hanging wires or duct tape. In the future, it might be possible to incorporate accelerometers inside bogie trains. Data processing can be automated, even to the point of real-time defect detection. On the other hand, further research will be needed in order to study other movement directions to characterize different types of defects, i.e. track alignment from lateral accelerations.

## Acknowledgements

The authors of this paper would like to thank FGV Alicante personnel for their collaboration, interest and kindness during this research.

## Appendix

Table A. Accelerometer PCB 354C02 specifications

Specifications	
Sensitivity	10 mV/g
Measurement range	± 500 g pk
Frequency range	0.5 to 2000 Hz
Resonant frequency	>12 kHz
Broadband resolution	0.0005 g rms
Temperature range	-65 to +250 °F
Excitation voltage	18 to 30 VDC

## References

- [1] Narayan V. Effective Maintenance Management. Risk and Reliability Strategies for Optimizing Performances. New York: Industrial Press, 2004.

- [2] **López Pita A.** Infraestructuras Ferroviarias. Barcelona: Ediciones UPC, 2006.
- [3] **Nagamuna Y., Kobayashi M., Nakagawa M., Okumura T.** Condition monitoring of Shinkansen tracks using commercial trains. 4th IET International Conference Railway Condition Monitoring, Derby, UK, 2008.
- [4] **Yazawa E., Takeshita K.** Development of measure device of track irregularity using inertial mid-chord offset method. Quarterly Report of Railway Technical Research Institute, Vol. 43, Issue 3, 2002, p. 125-130.
- [5] **Ahmadian M.** Filtering effects of mid-cord offset measurements on track geometry data. Proceedings of ASME/IEEE Joint Railroad Conference, 1999, p. 157-161.
- [6] **Boccione M., Caprioli A., Cigada A., Collina A.** A measurement system for quick rail inspection and effective track maintenance strategy. Mechanical Systems and Signal Processing, Vol. 21, Issue 3, 2007, p. 1242-1254.
- [7] **Mannara F., Barbati N.** Campagna sperimentale di misura delle accelerazioni sulle boccole delle sale di un treno ETR 220 della Ferrovia Circumvesuviana. Ingegneria Ferroviaria, Vol. 46, Issue 5, 2010, p. 449-467.
- [8] **Toliyat H. A., Abbaszadeh K., Rahimian M. M., Olson L. E.** Rail defect diagnosis using wavelet packet decomposition. IEEE Transactions on Industry Applications, Vol. 39, Issue 5, 2003, p. 1454-1461.
- [9] **Grassie S. L.** Measurement of railhead longitudinal profiles: a comparison of different techniques. Wear, Vol. 191, Issue 1-2, 1996, p. 245-251.
- [10] **Coudert F., Sunaga Y., Takegami K.** Use of axle box accelerations to detect track and rail irregularities. Proceedings of World Congress of Rail Research, 1999.
- [11] **Weston P. F., Ling C. S., Roberts C., Goodman C. J., Li P., Goodall R. M.** Monitoring vertical track irregularity from in-service railway vehicles. Journal of Rail and Rapid Transit, Vol. 221, Issue 1, 2007, p. 75-88.
- [12] **Mori H., Tsunashima H., Kojima T., Matsumoto A., Mizuma T.** Condition monitoring of railway track using in-service vehicle. Journal of Mechanical Systems for Transportation and Logistics, Vol. 3, Issue 1, 2010, p. 154-165.
- [13] **Real J., Salvador P., Montalbán L., Bueno M.** Determination of rail vertical profile through inertial methods. Journal of Rail and Rapid Transit, Vol. 225, Issue 1, 2010, p. 14-23.
- [14] **Mantenimiento de Infraestructuras Renfe. N. R. V. 7-3-5.5.** Calificación de Vía. Nivelación Longitudinal. Madrid: Centro de Publicaciones del Ministerio de Obras Públicas, 1983.
- [15] **Smith S. W.** The Scientist and Engineer's Guide to Digital Signal Processing. California: California Technical Publishing, 1997.
- [16] **García-Tejero F.** Topografía General y Aplicada. Madrid: Ediciones Mundi-Prensa, 2002.
- [17] **Davis P. J., Rabinowitz P.** Methods of Numerical Integration. San Diego: Academic Press, 1984.
- [18] **Boore D. M., Stephens C. D., Joyner W. B.** Comments on baseline correction of digital strong-motion data: examples from the 1999 Hector Mine, California, Earthquake. Bulletin of the Seismological Society of America, Vol. 92, Issue 4, 2002, p. 1543-1560.
- [19] **Melis M.** Introducción a la Dinámica Vertical de la Vía y Señales Digitales en Ferrocarriles. Madrid: Escuela de Ingenieros de Caminos Canales y Puertos, 2008.
- [20] **Romero R.** Métodos Estadísticos en Ingeniería. Valencia: Ediciones Universidad Politécnica de Valencia, 2005.
- [21] **Zimmerman Donald W.** A note on interpretation of the paired-samples t test. Journal of Educational and Behavioral Statistics, Vol. 22, Issue 3, 1997, p. 349-360.
- [22] **Comité Europeo de Normalización.** Aplicaciones Ferroviarias. Calidad Geométrica de la Vía. Parte 5: Niveles de Calidad Geométrica. UNE-EN 13848-5, 2009.