

# 791. A hybrid frequency response function formulation for MDOF nonlinear systems

E. Jamshidi<sup>1</sup>, M. R. Ashory<sup>2</sup>, A. Ghoddosian<sup>3</sup>, N. Nematipoor<sup>4</sup>

<sup>1,2,3</sup> Department of Mechanical Engineering, Semnan University, P. O. Box: 35195-363, Semnan, Iran

<sup>4</sup> Department of Mechanical Engineering, Semnan Branch, Islamic Azad University, Semnan, Iran

E-mail: <sup>1</sup>ehsan.jamshidi@semnan.ac.ir, <sup>2</sup>ashorymohammadreza@gmail.com,

<sup>3</sup>aghoddosian@semnan.ac.ir, <sup>4</sup>narjes.nematipoor@gmail.com

(Received 17 February 2012; accepted 14 May 2012)

**Abstract.** This paper introduces a hybrid technique for formulation of frequency response functions (FRFs) for nonlinear MDOF systems, based on the Structural modification using frequency response function (SMURF) technique. The technique can produce FRFs at the desired coordinates on the structure. The term “hybrid” indicates that the underlying linear system is reduced by expressing it in FRF form, while the nonlinearities are treated in the form of describing functions based on spatial elements. The method uses several FRFs instead of the spatial model therefore it is characterized by lower computational costs. Moreover, the experimentally measured FRFs of the underlying linear structure can be applied in this technique. A system with cubic stiffness and friction damping nonlinearities is used as a numerical case study to verify the proposed technique.

**Keywords:** nonlinear dynamics, MDOF system, FRF, DFM, SMURF, frequency domain.

## Introduction

In modal analysis a set of FRFs is used to derive a mathematical model of a structure. At present this experimental method is a well-established procedure for identification of linear systems [1, 2]. However, in the presence of nonlinearity, derivation of a general nonlinear model from FRF measurements is a cumbersome task and has yet to be found. It makes the establishment of a general nonlinear methodology difficult and as a result most of the proposed methods only deal with nonlinearity for specific cases.

One of the main obstacles when calculating the responses of a nonlinear structure, in theoretical approaches such as harmonic balance method (HBM), is that due to the coupled nature of nonlinear problems, all responses are computed simultaneously. When dealing with a large system, this results in a costly optimization problem with large number of unknowns [3, 4].

In practice, it is not possible to measure the responses at all DOFs due to the physical inaccessibility or the difficulties faced in the measurement of rotational DOFs. Therefore, a limited number of FRFs are available from measurement for comparison purposes. While the conventional theoretical methods produce a large number of FRFs, it makes sense to develop a formulation for obtaining the theoretical responses only at the limited measured coordinates, which results in reduction of a the number of nonlinear equations to be solved.

Kuran and Ozguven [5] and Tanrikulu et al. [6] used the describing function method (DFM) to achieve a matrix description of the nonlinearities. The use of the DFM is further documented in [7-11]. Chong and Imregun [12-14] used first-order describing function to identify nonlinear eigenvalues and eigenvectors of resonant modes. The method is equivalent to a nonlinear modal superposition and is compatible with existing linear modal analysis tools. Elizalde and Imregun [15, 16] attempted to deal with the problem of obtaining the theoretical responses at a few coordinates, using the first order describing function. They obtained closed form expression for frequency response functions of a nonlinear MDOF system. Considering cubic stiffness and friction damping nonlinearities, they showed that the method can successfully predict the nonlinear behavior of real structures. However, such an advantage is not so attractive

considering the heavy computational burden incurred, due to direct manipulation of mass, stiffness and damping coefficients.

This paper introduces a technique for formulation of FRF of MDOF nonlinear systems for selected coordinates, called hybrid formulation (HF). In this approach, the system is separated into underlying linear system and nonlinear components, where the last is based on discrete representation of the nonlinearities (typically stiffness and/or damping related), which are amplitude-dependent. The nonlinear components are replaced by their reaction forces on the underlying linear system. The term hybrid arises from this fact that the underlying linear system has been reduced by expressing it in the FRF form, while the nonlinearities are kept in the physical domain (in the form of describing functions). Then, the nonlinear responses are obtained via solving a set of nonlinear algebraic equations, which is usually solved by a Newton-Raphson scheme, or more specialized algorithms. As the method uses only a few numbers of FRFs from the underlying linear system instead of the spatial model, it has lower computational cost compared to the methods like HBM, which requires the computation of all the responses at once. The proposed technique has been programmed in MATLAB [17] and a modified Newton-Raphson approach was used to deal with a large set of nonlinear equations, incorporating the so-called trust-regions and pre-conditioned gradients (PCG) [18-20].

The method computes the response at the selected coordinates only, which is the prime advantage, especially when dealing with large nonlinear structures or in an experimental identification procedure, due to reduction of the computational cost. Moreover, it can use the experimentally derived FRFs, so that the errors related to the modeling of the system can be eliminated.

## Theory

$N$ -DOF nonlinear mass spring system is depicted in Fig. 1a. Fig. 2a shows its underlying linear system which can be obtained by removing nonlinear elements between the  $i^{th}$  and  $r^{th}$  DOFs ( $Nl-el_{ir}$ ) and between the  $s^{th}$  DOF and the ground ( $Nl-el_s$ ).

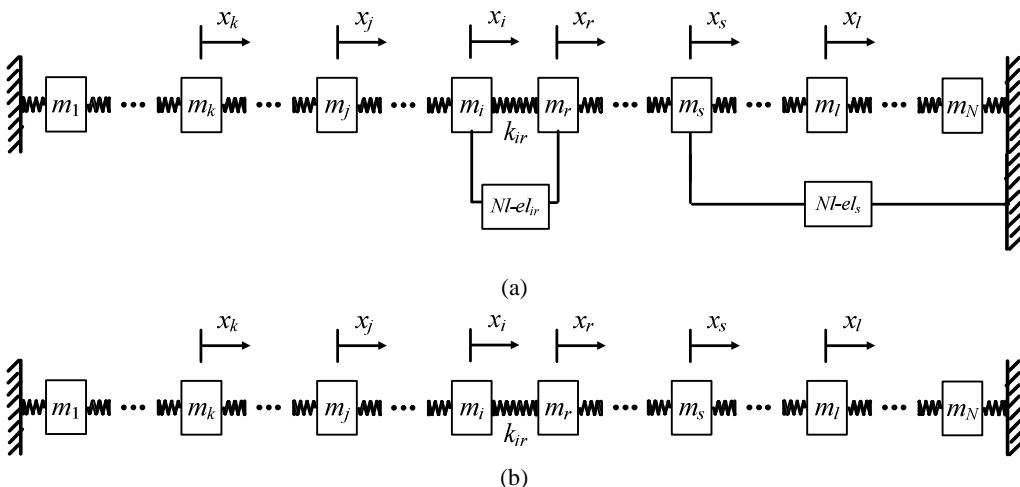


Fig. 1. (a)  $N$ -DOF nonlinear system, (b) underlying system

Fig. 2 illustrates the free body diagram of the system, where the nonlinear action and reaction forces between the underlying linear system and the nonlinear elements  $Nl-el_{ir}$  and  $Nl-el_s$  are presented. If the system is excited at  $k^{th}$  DOF and the response is measured at  $l^{th}$  DOF, the governing equation for the experimental system can be given by:

$$\tilde{x}_l = \alpha_{lk} F_k + \alpha_{ls} \tilde{R}_s + \alpha_{li} \tilde{R}_i + \alpha_{lr} \tilde{R}_r \quad (1)$$

where  $\tilde{x}_l$  is the displacement of  $l^{th}$  DOF of the system shown in Fig. 1a. The nonlinear nature of the system is acknowledged by a “~” symbol on top.  $\alpha_{lk}$ ,  $\alpha_{lj}$ ,  $\alpha_{ls}$  and  $\alpha_{lr}$  are the receptances of the underlying linear system (Fig. 1b).  $F_k$  is the excitation force and  $\tilde{R}_r$ ,  $\tilde{R}_i$  and  $\tilde{R}_s$  are the reaction forces of the added components at  $r^{th}$ ,  $i^{th}$  and  $s^{th}$  DOFs respectively. According to Newton’s third law:

$$\tilde{R}_i = -\tilde{R}_r \quad (2)$$

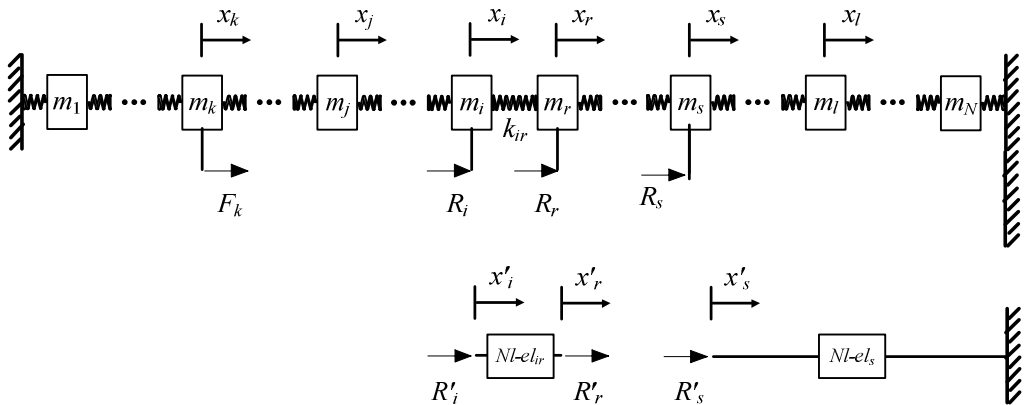


Fig. 2. Free body diagram of the  $N$ -DOF system

Defining  $\tilde{R}_{ir} = \tilde{R}_i = -\tilde{R}_r$  and substituting  $\tilde{R}_i$  and  $\tilde{R}_r$  by  $\tilde{R}_{ir}$  and  $-\tilde{R}_{ir}$  respectively according to the Eq. (2) in Eq. (1), we have:

$$\tilde{x}_l = \alpha_{lk} F_k + \alpha_{ls} \tilde{R}_s + (\alpha_{li} - \alpha_{lr}) \tilde{R}_{ir} \quad (3)$$

If the response  $\tilde{x}$  is sufficiently close to a pure sinusoid and provided that little energy is leaked to frequencies other than the fundamental, then it is reasonable to assume that the nonlinear function  $\tilde{R}$  is also of a periodically oscillating nature. It is possible to find a linearized coefficient  $\tilde{\nu}$  which provides the best average of the true restoring force. This coefficient acts on the fundamental harmonic of the nonlinear response ( $\tilde{x}^{1st}$ ) for a single load-cycle, in such a way that:

$$\tilde{R} \approx \tilde{\nu} \tilde{x} \quad \tilde{x} \approx \tilde{x}^{1st} \sin(\omega t + \theta) = \tilde{x}^{1st} \sin \tau \quad (4)$$

In order to find the nonlinear coefficient  $\tilde{\nu}$ , the restoring force  $\tilde{R}$  is expanded around  $\tilde{x}$  via a Fourier series, neglecting all the higher-order terms:

$$\tilde{R} \approx \tilde{\nu} \tilde{x} = \sigma_a^{1st} \tilde{x} + \sigma_b^{1st} \tilde{x} + \underbrace{\sigma_c^{2st} \tilde{x} + \sigma_d^{2st} \tilde{x} + \dots}_{\text{Neglected terms}} \quad (5)$$

where the  $\sigma$  functions are given by:

$$\sigma_a^{1st} = \frac{1}{\pi \tilde{x}^{1st}} \int_0^{2\pi} \tilde{g}(\tilde{x}^{1st} \sin \tau, \omega \tilde{x}^{1st} \cos \tau) \sin \tau d\tau$$

$$\sigma_b^{1st} = \frac{1}{\pi \tilde{x}^{1st}} \int_0^{2\pi} \tilde{g}(\tilde{x}^{1st} \sin \tau, \omega \tilde{x}^{1st} \cos \tau) \cos \tau d\tau$$
(6)

so the nonlinear coefficient  $\tilde{\nu}$  is uniquely defined by:

$$\tilde{\nu} = \sigma_a^{1st} + \sigma_b^{1st}$$
(7)

Introducing Eq. (4) into Eq. (3) yields:

$$\tilde{x}_l = \alpha_{lk} F_k - \alpha_{ls} \tilde{\nu}_s(\tilde{x}_s) \tilde{x}_s - (\alpha_{li} - \alpha_{lr}) \tilde{\nu}_{ir}(\tilde{x}_i - \tilde{x}_r) (\tilde{x}_i - \tilde{x}_r)$$
(8)

Setting  $F_k$  to be constant for all the frequency range and dividing both sides by  $F_k$ , we have:

$$\tilde{\alpha}_{lk}^* = \alpha_{lk} - \alpha_{ls} \tilde{\nu}_s(\tilde{x}_s) \tilde{\alpha}_{sk}^* - (\alpha_{li} - \alpha_{lr}) \tilde{\nu}_{ir}(\tilde{x}_i - \tilde{x}_r) (\tilde{\alpha}_{ik}^* - \tilde{\alpha}_{rk}^*)$$
(9)

where  $\tilde{\alpha}_{lk}^*$ ,  $\tilde{\alpha}_{sk}^*$ ,  $\tilde{\alpha}_{ik}^*$  and  $\tilde{\alpha}_{rk}^*$  are the receptances of the nonlinear system.

If  $p$  nonlinear elements were between the DOFs  $(i, r) = (i_1, r_1), (i_2, r_2), \dots, (i_p, r_p)$  and  $q$  nonlinear elements were between the DOFs  $s = (s_1, s_2, \dots, s_q)$  and the ground, Eq. (8) and Eq. (9) are modified as:

$$\tilde{x}_l = \alpha_{lk} F_k - \sum_{s=s_1}^{s_q} \alpha_{ls} \tilde{\nu}_s(\tilde{x}_s) \tilde{x}_s - \sum_{ir=i_1r_1}^{i_p r_p} (\alpha_{li} - \alpha_{lr}) \tilde{\nu}_{ir}(\tilde{x}_i - \tilde{x}_r) (\tilde{x}_i - \tilde{x}_r)$$
(10)

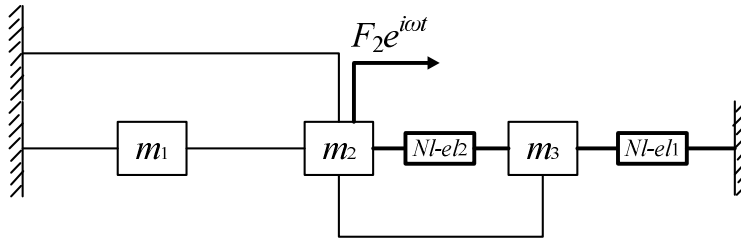
$$\tilde{\alpha}_{lk}^* = \alpha_{lk} - \sum_{s=s_1}^{s_q} \alpha_{ls} \tilde{\nu}_s(\tilde{x}_s) \tilde{\alpha}_{sk}^* - \sum_{ir=i_1r_1}^{i_p r_p} (\alpha_{li} - \alpha_{lr}) \tilde{\nu}_{ir}(\tilde{x}_i - \tilde{x}_r) (\tilde{\alpha}_{ik}^* - \tilde{\alpha}_{rk}^*)$$
(11)

Defining  $n$  as those DOFs associated with nonlinear elements,  $\{\tilde{x}\}$  can be split into  $n$  and  $(N-n)$  components. Expression (10) represents a system of  $n$  nonlinear equations ( $\tilde{x}_l$ , defined for the DOFs  $l \in n$ ) with  $n$  unknowns, the nonlinear responses at the  $n$  DOFs  $\{\tilde{x}_n\}$ , where typically  $n \ll N$ . This demonstrates that a nonlinear system can be fully described by first calculating the nonlinear responses at the  $n$  DOFs only. Once the nonlinear responses  $\{\tilde{x}_n\}$  are calculated, the problem has been reduced to a linear one. The remaining nonlinear responses  $\{\tilde{x}_{N-n}\}$  (responses of DOFs associated with linear elements) can be found all at once by solving equation (10) on an individual basis, for  $l \in (N - n)$ .

### Numerical case study

A three DOFs mass-spring system with two nonlinear components is considered here as the numerical case study (Fig. 3). The system is comprised of three masses, whose motion is defined at all times by the response coordinates  $y_1, y_2$  and  $y_3$ . The masses are linked to each

other and to the ground by the stiffness and damping linear elements, creating fully-populated linear matrices. The system is driven by a single harmonic force of constant amplitude imposed at mass  $m_2$ .



**Fig. 3.** Diagram for the analyzed sample cases

The numerical values for all the coefficients of the underlying linear system are shown below in matrix format, where a proportional hysteretic damping mechanism has been assumed:

$$M = \begin{bmatrix} m_1 & 0 & 0 \\ 0 & m_2 & 0 \\ 0 & 0 & m_3 \end{bmatrix} = \begin{bmatrix} 31.59 & 0 & 0 \\ 0 & 55.401 & 0 \\ 0 & 0 & 24.212 \end{bmatrix} \text{ kg,}$$

$$K = \begin{bmatrix} k_{11} & k_{12} & k_{13} \\ k_{21} & k_{22} & k_{23} \\ k_{31} & k_{32} & k_{33} \end{bmatrix} = \begin{bmatrix} 200491.263 & -64920.98 & -36279.371 \\ -64920.98 & 398118.365 & -17503.205 \\ -36279.371 & -17503.205 & 132578.825 \end{bmatrix} \frac{\text{N}}{\text{m}},$$

$$F = \begin{Bmatrix} F_1 \\ F_2 \\ F_3 \end{Bmatrix} = \begin{Bmatrix} 0 \\ 12 \\ 0 \end{Bmatrix} \text{ N,}$$

$\eta = 0.12 \%$ .

In addition to the linear system, two nonlinear elements have been incorporated, represented by the two thick links and boxes in Fig. 3. Both cubic stiffness and friction damping types are considered here. The numeric values of these coefficients are listed in Table 1. The nonlinear elements were placed in a way to provide a sufficiently general arrangement considering the size of the system. It has a mixture of grounded and non-grounded nonlinear elements, a nonlinear region comprised of DOFs 2 and 3, as well as a region away from nonlinearities, represented by DOF 1.

**Table 1.** Nonlinear coefficients for the Sample Cases 1 and 2

DOF	DOF	Sample Case 1 $\beta$ (N/m <sup>3</sup> )	Sample Case 2 $\gamma$ (N)	Type
1	1	-	-	-
1	2	-	-	-
1	3	-	-	-
2	2	-	-	-
2	3	$7.82 \cdot 10^6$	1.25	Non-grounded
3	3	$1.44 \cdot 10^7$	2.10	Grounded

The mathematical model of a cubic stiffness element can be expressed as:

$$\tilde{R} = ky + \beta y^3 \quad (12)$$

where the coefficient  $k$  represents the linear component of the spring, while the coefficient  $\beta$  accounts for the nonlinear effects due to the term  $y^3$ . Introducing (12) into (6), and dropping the superscript <sup>1st</sup> for the sake of clarity, we have:

$$\begin{aligned} \sigma_a &= \frac{1}{\pi Y} \int_0^{2\pi} (ky + \beta y^3) \sin \tau d\tau \\ \sigma_b &= 2 \sin(\pi) \cos(\pi) = 0 \end{aligned} \quad (13)$$

Introducing these functions into (7) and developing further (the subscript  $k$  in  $\tilde{v}_k$  meaning a stiffness-related coefficient):

$$\begin{aligned} \tilde{v}_k(\dot{y}, y) &= \frac{1}{\pi Y} \int_0^{2\pi} (kY \tilde{\sin} \tau + \beta Y^3 \tilde{\sin}^3 \tau) \sin \tau d\tau \\ \tilde{v}_k(\dot{y}, y) &= \frac{1}{\pi Y} \int_0^{2\pi} kY \tilde{\sin}^2 \tau + \frac{1}{\pi Y} \int_0^{2\pi} \beta Y^3 \tilde{\sin}^4 \tau d\tau \\ \tilde{v}_k(\dot{y}, y) &= \frac{k}{\pi} \int_0^{2\pi} \tilde{\sin}^2 \tau + \frac{\beta Y^2}{\pi} \int_0^{2\pi} \tilde{\sin}^4 \tau d\tau \\ \tilde{v}_k(\dot{y}, y) &= \frac{k}{\pi}(\pi) + \frac{\beta Y^2}{\pi} \left(\frac{3}{4}\pi\right) \end{aligned} \quad (14)$$

and we finally arrive to the first-order representation of a cubic stiffness element:

$$\tilde{v}(\dot{y}, y) = k + \frac{3}{4} \beta Y^2 \quad (15)$$

where the nonlinear part of the coefficient is given by:

$$\tilde{v}(\dot{y}, y) = \frac{3}{4} \beta Y^2 \quad (16)$$

This linearized coefficient effectively averages the changes in the nonlinear function.

Developments hitherto apply to a grounded element in which its only coordinate in motion is  $y$ . If the nonlinear element is attached between two moving nodes  $y_1$  and  $y_2$  (meaning it is not grounded), a variable change is needed to apply the same procedure:

$$\begin{aligned} z &= y_1 - y_2, \quad y_1 = \tilde{Y}_1 \sin(\omega t + \Theta_1), \quad y_2 = \tilde{Y}_2 \sin(\omega t + \Theta_2), \\ z &= \tilde{Z} \sin(\omega t + \Theta_z) = \tilde{Z} \sin \tau, \quad \tilde{Z} = |z| = |y_1 - y_2|, \quad \Theta_z = \angle(y_1, y_2), \end{aligned} \quad (17)$$

and the nonlinear restoring force becomes:

$$\tilde{g}(\dot{z}, z) \approx \tilde{v}_k(\dot{z}, z) z. \quad (18)$$

Introducing this variable change and applying a similar procedure, the following expression is readily available:

$$\tilde{v}_k(\dot{z}, z) = k + \frac{3}{4}\beta\tilde{Z}^2 \quad (19)$$

where the nonlinear part of the coefficient is given by:

$$\tilde{v}_k(\dot{z}, z) = \frac{3}{4}\beta\tilde{Z}^2 \quad (20)$$

The friction damping mechanism can be mathematically expressed as:

$$\tilde{g}(\dot{y}, y) = c\dot{y} + \gamma \frac{\dot{y}}{|\dot{y}|} \text{ for } y > \tilde{Y}_{Limit} \text{ (slip condition)} \quad (21)$$

where the  $|\dot{y}|$  term is used to ensure that the restoring force always opposes the direction of motion. This model is only valid during the “slip” stage, occurring at displacements over a certain limit  $\tilde{Y}_{Limit}$ , which is related to the properties of the surfaces in contact. Barely below this threshold a phenomenon known as “stick-slip” exists, which is characterized by intermittent motion and stationary behavior. Such a condition invalidates Eq. (21).

Following a similar approach as we did for the cubic stiffness nonlinearity, a first-order analysis of a friction damping element yields:

$$\tilde{v}_c(\dot{y}, y) = i\omega c + i \frac{4\gamma}{\pi\tilde{Y}} \quad (22)$$

For non-grounded nonlinear elements, the relevant describing function is:

$$\tilde{v}_c(\dot{z}, z) = i\omega c + i \frac{4\gamma}{\pi\tilde{Z}_{ij}} \quad (23)$$

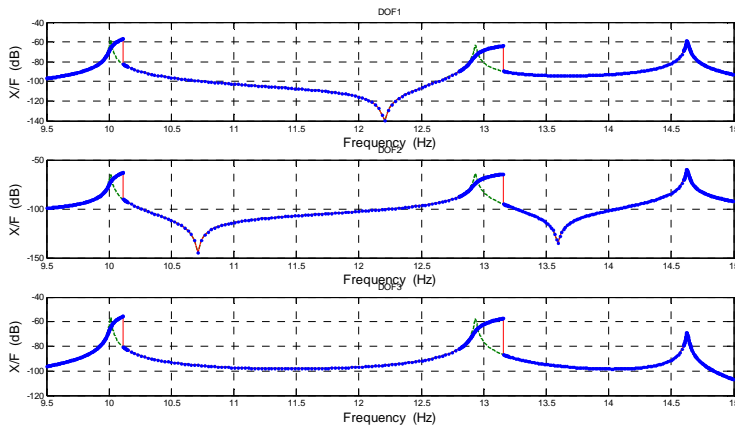
The imaginary number  $i$  in Eqs. (22) and (23) is used to introduce a phase lag between the restoring force and its correspondent physical displacement, given that this nonlinearity is velocity-dependent.

## Results and discussion

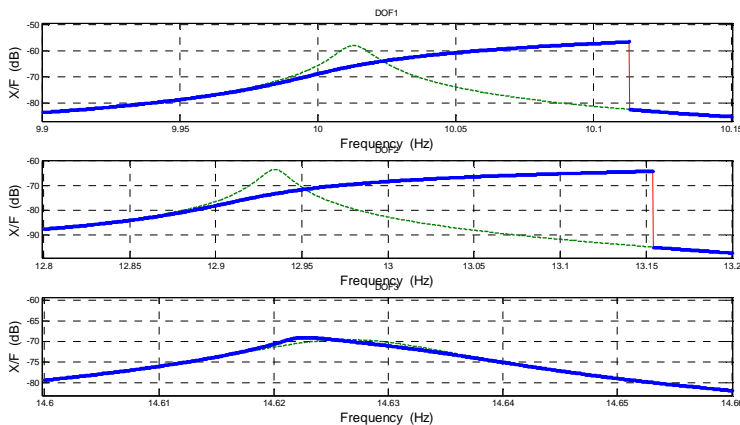
The nonlinear FRFs  $\frac{\tilde{Y}_1}{F_2}$ ,  $\frac{\tilde{Y}_2}{F_2}$  and  $\frac{\tilde{Y}_3}{F_2}$  together form a set of three complex nonlinear equations with three complex unknowns (the responses  $\tilde{Y}_1$ ,  $\tilde{Y}_2$  and  $\tilde{Y}_3$ ), valid for a single frequency  $\omega$ . The responses can be solved by using a standard Newton-Raphson algorithm. The performance of the proposed method will be compared with the harmonic balance method (HBM), which is a recognized benchmark for nonlinear problems. After applying the minimization process for every step frequency  $\Delta\omega$ , the nonlinear response is obtained and shown in Figs. 4-5 for the cubic stiffness case. Figs. 6 and 7 provide the results for the friction

damping case. The dashed lines represent the linear response, while the solid lines represent the results obtained from the harmonic balance method. Finally, the “•” marks are the results from the HF method. It can be observed that the HF method (“•” marks) is in complete agreement with the benchmark HBM (solid line), both exhibiting nonlinear distortions when compared to the linear case (dashed line).

For the cubic stiffness case, the effect of the nonlinearity is a jump phenomenon, being more noticeable in the first and second modes as indicated in Figs. 4 and 5. It is observed that the responses can be calculated at the resonant regions only, where the nonlinearities are expected to become active, everywhere else being replaced by the linear responses. The results for the friction damping case (Figs. 6-7) reveal that the effect of the nonlinearity is an overall reduction in the amplitudes, being more noticeable in the first and second modes. This explains why this nonlinear mechanism is so welcome (and even induced) in turbine bladed disks, where higher amplitudes are a risk for the structure stability. The third mode is less affected because, at higher frequencies, the nonlinear damping force is overwhelmed by the linear restoring forces; the more pronounced effect in the second mode can be explained by the fact that two masses are in opposite motion, generating an additive effect of the friction forces.

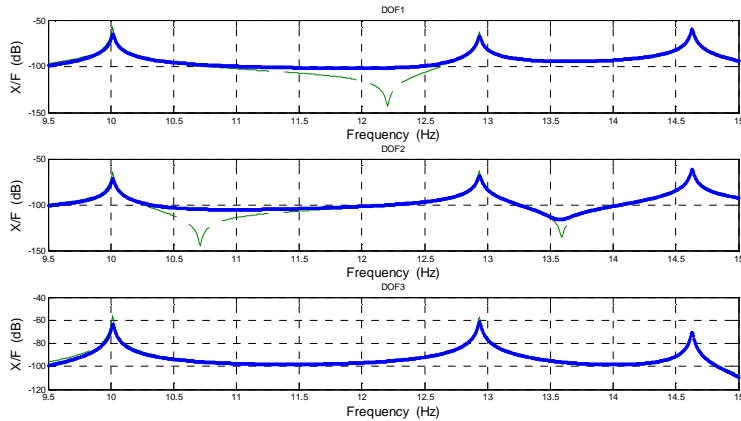


**Fig. 4.** FRFs of underlying linear system (---), nonlinear system via HF method (•), nonlinear system via HBM (—) for the cubic stiffness case (zoom-in of the resonances is shown in the next figure)

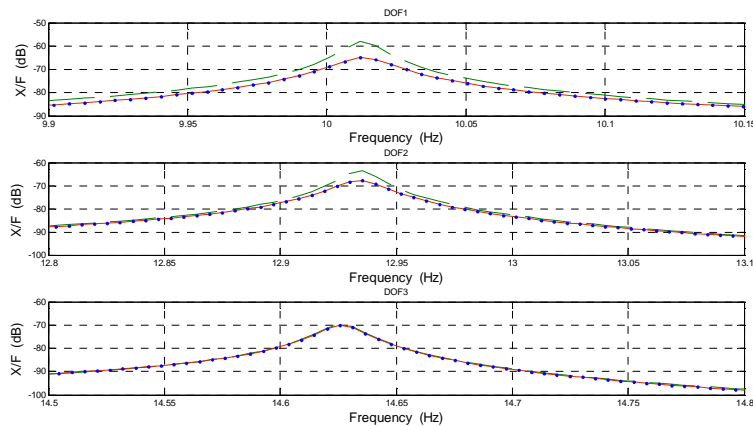


**Fig. 5.** Nonlinear FRFs for the cubic stiffness case (zoom-in of individual resonances)





**Fig. 6.** FRFs of underlying linear system (---), nonlinear system via HF method (\*), nonlinear system via HBM (—) for the friction damping case (zoom-in of the resonances are shown in the next figure)



**Fig. 7.** Nonlinear FRFs for the friction damping case (zoom-in of individual resonances)

## Conclusions

In this paper a technique for frequency response function formulation of nonlinear MDOF systems called hybrid formulation (HF) was proposed. The technique is based on Structural modification using frequency response function (SMURF) technique. The term hybrid indicates that the underlying linear system is reduced by expressing it in FRF form, while the nonlinearities are represented in the form of describing functions (physical domain). The nonlinear elements have been formulated based on an already proven “engine”, the describing function method (DFM). The introduced formulation neglects the existence of sub/super harmonics, this being one of our main assumptions. This assumption, while inaccurate for a time domain representation, works very well in the frequency domain, which considers average quantities in a single load-cycle.

The performance of the method was compared with the harmonic balance method (HBM), which is a recognized benchmark for nonlinear problems. The advantages of the proposed formulation were illustrated by analyzing two sample cases for which the theoretical nonlinear FRFs were obtained. While the results of the HF are in excellent agreement with the

benchmark, it has lower computational cost. It is due to this fact that the technique only produces FRFs at the desired coordinates. Also the method uses a few FRFs from underlying linear system, instead of the spatial model. Moreover as the method only needs FRFs of several coordinates, it can employ the experimentally derived FRFs for the underlying linear system.

## Acknowledgements

This work is supported by the Talented Office of Semnan University.

## References

- [1] **Ewins D. J.** Modal Testing: Theory, Practice and Application. Research Studies Press Ltd., London, 2000.
- [2] **Maia N., Silva J.** Theoretical and Experimental Modal Analysis. Research Studies Press Ltd., England, 1997.
- [3] **Sanliturk K. Y., Imregun M., Ewins D. J.** Harmonic balance vibration analysis of turbine blades with friction dampers. ASME Journal of Vibrations and Acoustics, Vol. 119, 1997, p. 96–103.
- [4] **Sanliturk K. Y., Imregun M., Ewins D. J.** Friction damper optimization for turbine blades: experimental and theoretical predictions. IMechE – Sixth International Conference in Vibrations in Rotating Machinery, 1996, p. 171–186.
- [5] **Kuran B., Ozguven H. N.** A modal superposition method for non-linear structures. Journal of Sound and Vibration, Vol. 189, Issue 3, 1996, p. 315–339.
- [6] **Tanrikulu O., Kuran B., Ozguven H. N., Imregun M.** Forced harmonic response analysis of non-linear structures. AIAA Journal, Vol. 31, 1993, p. 1313–1320.
- [7] **Van Der Pol B.** Forced oscillations in a circuit with non-linear resistance. The London, Edinburgh, and Dublin Philosophical Magazine and Journal of Science, Vol. 3, 1927, p. 65–80.
- [8] **Kul Y. H., Chen C. F.** A new method for evaluating the describing function of hysteresis-type nonlinearities. Journal of the Franklin Institute, Vol. 273, 1962, p. 226–241.
- [9] **Watanabe K., Sato H.** A modal analysis approach to nonlinear multi-degrees-of-freedom systems. ASME Journal of Vibrations, Stress and Reliability in Design, Vol. 189, Issue 3, 1988, p. 110–410.
- [10] **Rice H. J.** Identification of weakly non-linear systems using equivalent linearization. Journal of Sound and Vibration, Vol. 185, 1995, p. 473–481.
- [11] **Besancon-Voda A., Blaha P.** Describing function approximation of a two-relay system configuration with application to Coulomb friction identification. Control Engineering Practice, Vol. 10, 2002, p. 655–668.
- [12] **Chong Y. H., Imregun M.** Variable modal parameter identification for MDOF systems – Part 1: Formulation and numerical validation. Shock and Vibration, Vol. 7, 2000, p. 217–228.
- [13] **Chong Y. H., Imregun M.** Variable modal parameter identification for MDOF systems – Part 2: Experimental validation and advanced case study. Shock and Vibration, Vol. 7, 2000, p. 229–240.
- [14] **Chong Y. H., Imregun M.** Modal parameter extraction methods for non-linear systems. Proceedings of the 16th International Modal Analysis Conference, Vol. 1, 1998, p. 728–736.
- [15] **Elizalde H., Imregun M.** An explicit frequency response function formulation for multi-degree-of-freedom non-linear systems. Mechanical Systems and Signal Processing, Vol. 20, Issue 8, 2006, p. 1867–1882.
- [16] **Elizalde H.** Non-Linear Modal Analysis Methods for Engineering Structures. Ph. D. Thesis, Imperial College, London, 2004.
- [17] **Coleman T., Branch M. A., Grace A.** Optimization Toolbox for use with MATLAB 5.11. The MathWorks, Inc., 24 Prime Park Way, Natick, MA 01760-1500, 1999.
- [18] **Byrd R. H., Schnabel R. B., Shultz G. A.** Approximate solution of the trust region problem by minimization over two-dimensional subspaces. Mathematical Programming, Vol. 40, 1988, p. 247–263.
- [19] **Scales L. E.** Introduction to Non-Linear Optimization. Macmillan Publishers Ltd., England, 1985.
- [20] **Nazareth J. L.** The Newton-Cauchy Framework. Springer-Verlag, Germany, 1994.