

708. Simple friction model of the guiding device of a mechanical system: mass, spring and damper

B. Janecek¹, V. Kracik², J. Skliba³, Z. Herda⁴, M. Marek⁵, J. Buchta⁶

Technical University of Liberec, Czech Republic

E-mail: ¹bedrich.janecek@tul.cz, ²vladimir.krakik@tul.cz, ³jan.skliba@tul.cz,
⁴zdenek.herda@gmail.com, ⁵martin.marek@email.cz, ⁶jaroslav.buchta@tul.cz

(Received 3 September 2011; accepted 4 December 2011)

Abstract. The paper presents a simple friction model containing two parts: dry and viscous friction. Friction model is built inside the model of the guiding device of a mechanical system consisting of a mass, linear spring and damper. System is excited by the movement of the base. Main idea of the presented algorithm is to split up the solution into several parts, which follow one after another in time, and to combine their results subsequently.

Keywords: vibrations, mechanical system, dry friction, software implementation of friction model, Matlab.

Introduction

A simple static friction model is considered in this paper. It consists of two components: dry and viscous friction. Dry friction is subdivided into static and kinetic one. Static friction is also called stiction [1]. The static friction is present in a guiding mechanism that is at rest, while the kinetic one - in case of moving mechanism. During movement of a guiding mechanism the relative stroke – distance $z_2(t) - z_1(t)$ is changed (Fig. 1).

System description

A mechanical system including mass, damper and spring is considered. This system is complemented by the guide scissors mechanism (Fig. 1). The system is excited by moving the base, whose position is z_1 .

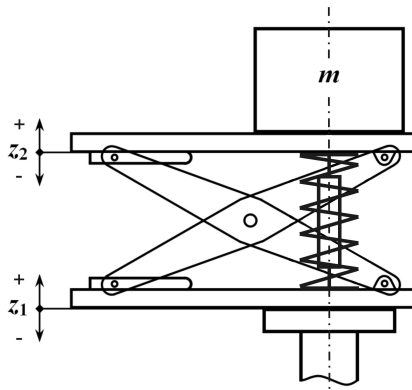

Fig. 1. Mass, spring and damper with the scissors guide mechanism

In the system we assume a linear spring and a linear damper. The variables z_1 and z_2 are used for the description of the system. Variable z_2 is the deviation from the equilibrium position, which is determined by the size of mass m and stiffness of the spring. In initial position the variable z_1 will be zero. The initial value of variable z_2 can be, but must not be zero. Initial values of the first derivatives of these variables for the described model are assumed

to be zero. In the following text we will denote the spring force F_s , which shall be the deviation of spring power from the equilibrium value. The real initial spring power is $-mg$, g is the gravitational constant.

As already mentioned, the system in Fig. 1 is excited by moving the base with position z_1 . It means that we know the time behavior of $z_1(t)$, $v_1(t) = \frac{dz_1(t)}{dt}$ and $a_1(t) = \frac{d^2z_1(t)}{dt^2}$ for $t \geq 0$.

Let us designate $z_r(t) = z_2(t) - z_1(t)$, $v_r(t) = \frac{dz_r(t)}{dt} = \frac{dz_2(t)}{dt} - \frac{dz_1(t)}{dt}$, where:

$z_r(t)$ is the relative stroke,

$v_r(t)$ is the speed of relative stroke, or the relative speed.

We assume that the friction force in the mechanism is approximately determined by the function from Fig. 2.

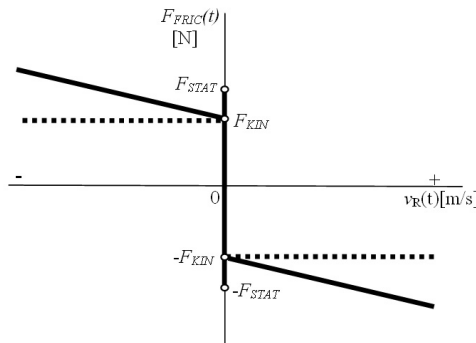

Fig. 2. Friction force as a function of relative velocity

The forces between the mass and the scissors mechanism are drawn in Fig. 3.

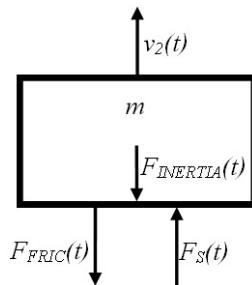

Fig. 3. Forces acting on the mass m from Fig. 1

The upward direction of forces and movement are considered as positive.

$$F_{INERTIA}(t) = -m \frac{d^2z_2(t)}{dt^2}, \quad F_{INERTIA}(t) \text{ is the inertial force,} \quad (1)$$

$$F_s(t) = -k_s z_r(t), \quad F_s(t) \text{ is the force of the spring,} \quad (2)$$

$$F_{FRIC}(t) = F_{DRY}(t) + F_{VIS}(t), \quad F_{FRIC}(t) \text{ is the friction force.} \quad (3)$$

In the case of movement of scissors mechanism, $v_r(t) \neq 0$,

$$F_{DRY}(t) = -\text{sign}(v_r(t)) F_{KIN}, \quad F_{DRY}(t) \text{ is the force of dry friction,} \quad (4)$$

$$F_{VIS}(t) = -k_{VIS} v_r(t), \quad (5)$$

$F_{VIS}(t)$ is the viscous force of damper and guide mechanism.

The force $F_{VIS}(t)$ consists of two elements: viscous friction of guide mechanism and viscous force of the damper.

Vector $F_{INERTIA}(t)$ in Fig. 3 is drawn for the case $\frac{dv_2(t)}{dt} > 0$, vector $F_S(t)$ for $z_R(t) < 0$ and vector $F_{FRIC}(t)$ for $v_R(t) > 0$.

$F_{FRIC}(t)$ is the sum of two forces (see (3)).

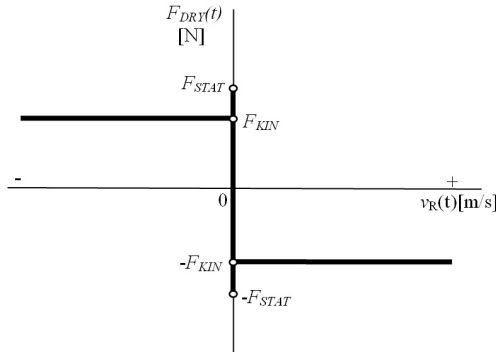

Fig. 4. Dry friction force as a function of relative velocity

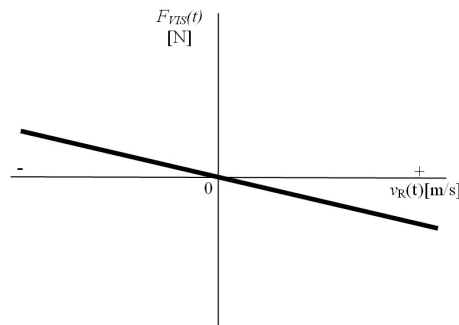

Fig. 5. Viscous friction force as a function of relative velocity

The characteristic of the dry friction is nonlinear. The discussed system in the model calculation passes between “basic states” with non-zero time duration. In one of the basic states the relative speed is zero, $v_R(t) = 0$, system is stuck – locked and in the second state the speed is nonzero $v_R(t) \neq 0$ and $sign(v_R(t))$ does not change, system is released.

Movement of the system in the released state when $v_R(t) \neq 0$ is described with the equations:

$$F_{INERTIA}(t) + F_S(t) + F_{DRY}(t) + F_{VIS}(t) = 0, \quad (6)$$

$$m \frac{d^2 z_2(t)}{dt^2} + k_s z_R(t) + sign(v_R(t)) F_{KIN} + k_{VIS} v_R(t) = 0 \quad (7)$$

In equation (7), describing the dynamics of the system of Fig. 1, the dynamics of the scissors mechanism is neglected. Inertial moments of the arms of the scissors mechanism in the mathematical model are considered to be zero. They could be neglected because the loading mass m is much greater than the mass of the arms of the scissors mechanism (ten times greater in the case of the investigated nonlinear system with the air-spring).

In “basic locked state” when $v_R(t) = 0$ movement of the system is also described with (6), but:

$$\frac{dz_2(t)}{dt} = \frac{dz_1(t)}{dt} \quad (8)$$

and

$$\frac{d^2 z_2(t)}{dt^2} = \frac{d^2 z_1(t)}{dt^2}, \quad (9)$$

$$F_s(t) \text{ is constant, } F_s(t) = F_s \text{ const,}$$

$$F_{vis}(t) = 0,$$

$$F_{FRIC}(t) = F_{DRY}(t), \quad (10)$$

$$F_{INERTIA}(t) = -m \frac{d^2 z_1(t)}{dt^2} = -m \frac{d^2 z_2(t)}{dt^2}.$$

We can rewrite (6):

$$F_{INERTIA}(t) + F_s \text{ const} + F_{DRY}(t) = 0 \quad (11)$$

$$F_{DRY}(t) = -F_{INERTIA}(t) - F_s \text{ const}$$

The development of $z_2(t)$ is calculated by integration of known $\frac{dz_1(t)}{dt}$, with initial value, which is equal to the final value $z_2(t)$ from the previous “basic state”.

First testing of the friction simulating algorithm was performed by the program that used harmonic excitation signal $z_1(t)$ with constant amplitude A and linearly increasing frequency (chirp signal), $\omega(t) = k_\omega t$ for $t \in (0, T_{\max})$, $\omega_{\max} = k_\omega T_{\max}$.

$$z_1(t) = A \sin(k_\omega t^2), \quad (12)$$

$$\frac{dz_1(t)}{dt} = 2 A k_\omega t \cos(k_\omega t^2), \quad (13)$$

$$\frac{d^2 z_1(t)}{dt^2} = 2 A k_\omega (\cos(k_\omega t^2) - 2 k_\omega t^2 \sin(k_\omega t^2)). \quad (14)$$

Let us discuss the case of chirp excitation signal with zero initial conditions, $z_1(0) = 0$ and $\frac{dz_1(0)}{dt} = 0$. The initial acceleration of $z_1(t)$ is $\frac{d^2 z_1(0)}{dt^2} = 2 A k_\omega$. Let the next initial condition of system be $z_2(0) = 0$ and $\frac{dz_2(0)}{dt} = 0$. The initial value of the spring force is, in this case,

$$F_s(0) = 0. \text{ Let us consider, that } k_\omega \text{ was chosen in such a way as to have } \text{abs}\left(m \frac{d^2 z_1(0)}{dt^2}\right) < F_{STAT},$$

i.e. relative movement of the system at the beginning is zero, $v_R(0) = 0$. In this case, when the frequency of the excitation signal increases, system passes through the discussed two “basic states” several times, relative movement is several times stuck – locked and then released. When the frequency increases the system comes to the states, where signs of $v_R(t)$ changes and the system is still released. System no longer comes to the “locked basic state”.

Let us describe the system movement with the text structure which will be close to the structure of the program. We designate the beginning time t_1 . The presented friction model starts from initial conditions $z_1(t_1) = 0$, $\frac{dz_1(t_1)}{dt} = 0$ and $\frac{dz_2(t_1)}{dt} = 0$. It means that $v_R(t_1) = 0$. The initial condition $z_2(t_1)$ and parameters of the model (i.e. m , k_s , k_{vis} , F_{STAT} , F_{KIN} , A , k_ω and stop – final time T_{\max}) can be set to arbitrary values in the program.

The second derivation of z_1 of chirp signal at time $t=0$ is non zero, $\frac{d^2 z_1(0)}{dt^2} = 2 A k_\omega$. For $t > 0$ is $\frac{d^2 z_1(t)}{dt^2}$ smooth – continuous function. The same property has to valid for any other excitation function, which can be built in the discussed model of the system with friction. The friction model which can work with excitation signal with discontinuous $\frac{d^2 z_1(t)}{dt^2}$ will be worked out as well.

For simplicity of explanation, the program behavior is described only with a simpler model that is specified as follows. The movement of the system is solved for $z_2(0)=0$ and k_ω is chosen so that $abs\left(m \frac{d^2 z_1(0)}{dt^2}\right) < F_{STAT}$. The system at the beginning time $t_1=0$ is stuck – locked.

- 1) We set initial values $z_1(t_1)=0$, $\frac{dz_1(t_1)}{dt}=0$, $z_2(t_1)=0$, $\frac{dz_2(t_1)}{dt}=0$. The variables $\frac{d^2 z_1(t_1)}{dt^2}$ and $\frac{d^2 z_2(t_1)}{dt^2}$ must be known for model computation. Their values at time t_1 are $\frac{d^2 z_1(t_1)}{dt^2} = \frac{d^2 z_2(t_1)}{dt^2} = 2 A k_\omega$, see (9) and (14),
- 2) if $abs\left(m \frac{d^2 z_1(t_1)}{dt^2} + k_s z_R(t_1)\right) < F_{STAT}$ (15)

Then starts the solution of movement of the system, which is in “locked basic state” i.e. $v_R(t)=0$, $z_R(t)$ is constant. The solution of the locked system will be performed until time t_2 , when the condition

$$abs\left(m \frac{d^2 z_1(t_2)}{dt^2} + k_s z_R(t_2)\right) = F_{STAT}, \quad (16)$$

is fulfilled.

After finishing the solution of “locked basic state” we will compute the variable

$$F_{KINLAST} = sign\left(m \frac{d^2 z_2(t_2)}{dt^2} + k_s z_R(t_2)\right) F_{KIN}, \quad (17)$$

which will be used in part 3) of the program, we set $t_1 = t_2$, otherwise the system does not come in “locked basic state”.

For the use in 3) we will compute

$$F_{KINLAST} = -sign\left(m \frac{d^2 z_2(t_1)}{dt^2} + k_s z_R(t_1)\right) F_{KIN}, \quad (18)$$

and

- 3) the system comes in “basic released state” $v_R(t) \neq 0$ and during this “basic state” the sign of $v_R(t)$ does not change, $F_{DRY}(t)$ is constant,

$$F_{DRY}(t) = F_{KINLAST}. \quad (19)$$

Eq. (4) for computing of $F_{DRY}(t)$ cannot be used. Therefore $v_R(t)=0$ at the beginning of “released state”. Explanation of (17) and (18) will be made in the following text. Movement of the system is described with the equation

$$m \frac{d^2 z_2(t)}{dt^2} + k_s z_R(t) + F_{KINLAST} + k_{VIS} v_R(t) = 0. \quad (20)$$

Basic state $v_R(t) \neq 0$ will be solved until time t_3 , when speed comes to zero,

$$v_r(t_3) = 0, \tag{21}$$

put $t_1 = t_3$ and go to 2).

The algorithm will terminate at the specified final time T_{max} .

Conditions (16) and (21) are tested in Simulink procedures with the use of “Hit Crossing” blocks. If they are satisfied, the simulation is stopped using “Stop Simulation” blocks. For proper function of these procedures we can not use “Derivative” blocks. “Hit Crossing” block uses iterative procedure to find an exact instant of time when the condition is satisfied. If we would like to excite the system with external data, the time interpolation in external data must be made in Matlab after finishing the Simulink procedure.

In the previous description of the program, the use of condition (15) in case of $v_r(t_1) = 0$ is physically obvious. Depending on whether this condition is fulfilled or not, the system comes to “locked state” or “released state”.

The computation of “released basic state” $v_r(t) \neq 0$ of the system begins at time t_1 , see part 3) of program description. Let us consider that we use eq. (4) for computation of $F_{DRY}(t_1)$. At time t_1 , $v_r(t_1) = 0$, $sign(0) = 0$. This results in $F_{DRY}(t_1) = 0$, which is wrong. $F_{DRY}(t_1)$ must be computed from the end of the previous “basic state”. Previous “basic state” could be locked, or released.

a) At first let us discuss, that previous “basic state” was locked. In the case of “locked basic state” $F_{DRY}(t)$ changes in interval $(-F_{STAT}, F_{STAT})$. In Fig. 4, $F_{DRY}(t)$ moves only on vertical axis, eq. (11) holds. The time, when $F_{DRY}(t)$ comes on borders of the mentioned interval was designated t_2 in part 2) of program description. At time t_2 either $F_{DRY}(t_2) = -F_{STAT}$ or $F_{DRY}(t_2) = F_{STAT}$. In next time, $t > t_2$ the system comes to “released basic state” and $F_{DRY}(t)$ starts to be either $F_{DRY}(t) = -F_{KIN}$ or $F_{DRY}(t) = F_{KIN}$. In the discussed time development, in time $t \geq t_2$, the $sign$ of $F_{DRY}(t)$ does not change. For this reason $sign(F_{DRY}(t))$ in the “released basic state” is the same as $sign(F_{DRY}(t_2))$ at the end of the previous “locked basic state”. This fact is expressed in eq. (17) and (19).

b) Let us discuss the second variant, when the system comes to the “released basic state” from the previous “released basic state”. If $v_r(t)$ was positive in the previous “released basic state”, it becomes negative in the next “released basic state” and vice versa. The change of signs of $F_{DRY}(t)$ is expressed in eq. (18) and (19).

Structure of Matlab – Simulink program

It may seem from the previous text that the discussed algorithm can be implemented in Simulink as consisting of two subroutines. First subroutine for solving “basic locked state” when $v_r(t) = 0$ and the second subroutine for solving “basic released state” when $v_r(t) \neq 0$. But the problem is, that second subroutine ought to start and finish, see (21), with zero relative movement. For this reason it was necessary to divide this subroutine into two subroutines (but with very similar structure). For the solution of the discussed algorithm we worked out three subroutines in Simulink.

Parameters for test of the system with chirp excitation signal

The system with friction was tested by a program in MATLAB with parameters:

$$m = 100 \text{ kg}, \quad k_{vrs} = 200 \frac{Ns}{m}.$$

Spring constant k_s was chosen so that the natural frequency of the undamped system is:

$$f_n = 1.5 \text{ Hz}, \quad \omega_n = 2\pi f_n, \quad k_s = m \omega_n^2 \approx 8883 \frac{\text{N}}{\text{m}}, \quad F_{\text{STAT}} = 26 \text{ N}, \quad F_{\text{KIN}} = 18 \text{ N}.$$

The calculation was finished at time $T_{\text{max}} = 9.5 \text{ s}$.

For excitation the amplitude of “chirp signal” was $A = 0.05 \text{ m}$ and maximal frequency $f_{\text{max}} = 0.825 \text{ Hz}$.

Coefficient k_ω ought to be computed from equation:

$$k_\omega = \frac{\omega_{\text{max}}}{2 T_{\text{max}}} = \frac{\pi f_{\text{max}}}{T_{\text{max}}}. \quad (22)$$

For our test:

$$k_\omega = \frac{\omega_{\text{max}}}{2 T_{\text{max}}} = \frac{\pi f_{\text{max}}}{T_{\text{max}}} \approx 0.2728.$$

Simulation results

Simulation results are presented in Fig. 6-9.

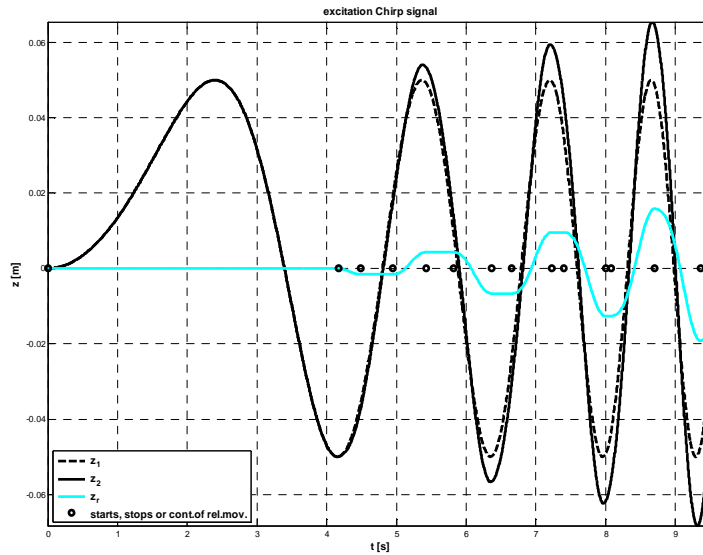

Fig. 6. System excited with „chirp“ signal, z_1 is dashed black, z_2 is full black, z_r is grey, circles are time borders between the basic states

Conclusions

The friction model proposed in this paper is a static model with stiction, dry and viscous frictions. This model was used as a part of simulation of a system that was otherwise linear. The excitation was executed with the smooth time function generated in Simulink. In the future we would like to use this friction model as part of a more complicated nonlinear model including an air–spring. This model will be excited with the measured data for the purpose of identification.

We offer the software (in Matlab 2007) that was shortly described in this paper as a freeware. It can be sent to interested persons upon e-mail request.

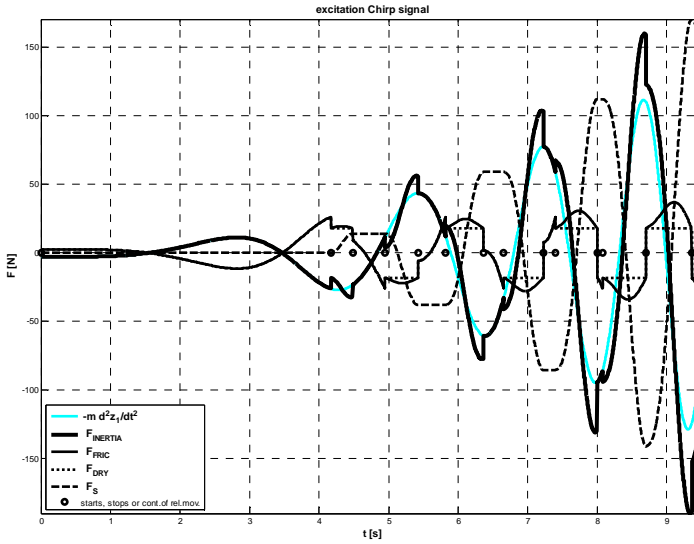

Fig. 7. System excited with the „chirp“ signal, $F_{INERTIA}$ is thick, F_{FRIC} is thin, F_{DRY} is dotted, F_S is dashed, force $-m \frac{d^2 z_1}{dt^2}$ is grey, circles are time borders between the basic states

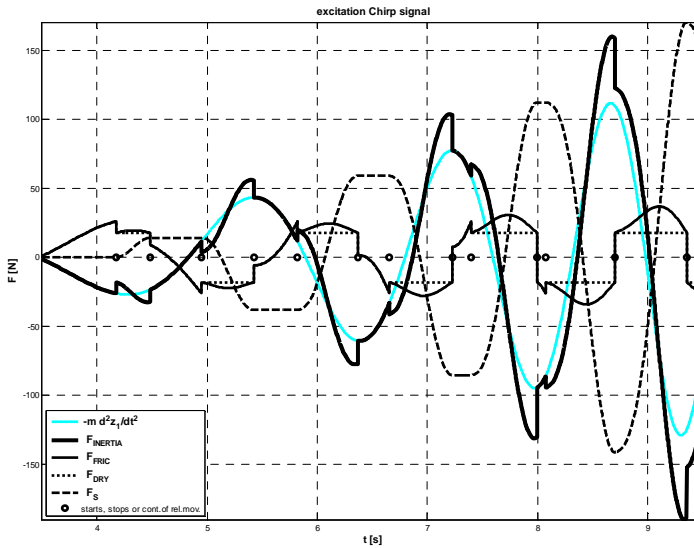

Fig. 8. Time zoom of Fig. 7

Acknowledgment

This research was supported by the Ministry of Education of the Czech Republic under contract No. MSM 4674788501 “Optimization of Machine Properties in Interaction with Working Processes and Human Aspects”.

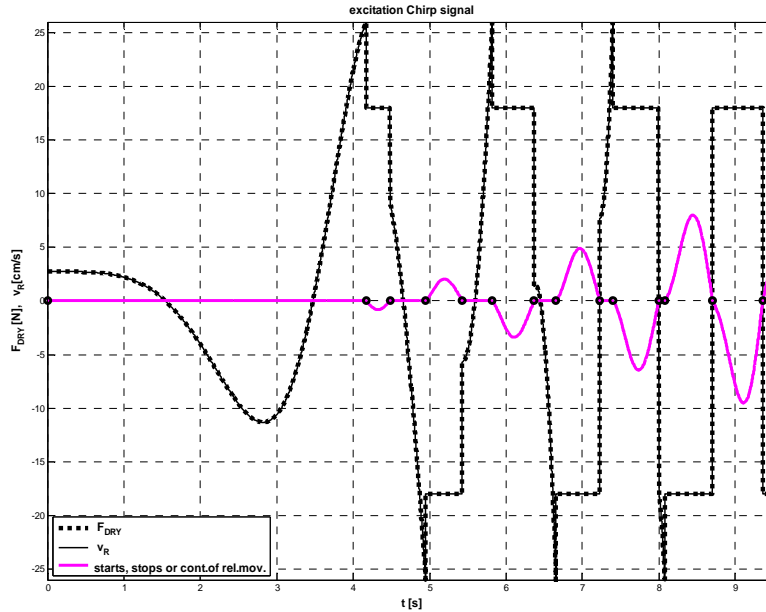

Fig. 9. System excited with „chirp“ signal, F_{DRY} is dotted, v_R is grey, circles are time borders between the basic states

References

- [1] H. Olsson, K. J. Aström, C. Canudas de Wit, M. Gäfvert, P. Lischinsky Friction Models and Friction Compensation. European Journal of Control, Dec. 1998, No. 4, p. 176-195.
- [2] C. Canudas de Wit, H. Olsson, K. J. Aström, P. Lischinsky A New Model for Control of Systems with Friction. IEEE Transactions on Automatic Control, March 1995, Vol. 40, No. 3, p. 419-425.