

704. Effect of epoxy and polyurethane coating modification with nanofillers on their resistance to erosive wear

Danuta Kotnarowska¹, Michał Przerwa², Małgorzata Wojtyniak¹

¹Department of Mechanical Engineering, Technical University of Radom
al. Chrobrego 45, 26-600 Radom, Poland

²Technical University of Radom, al. Chrobrego 45, 26-600 Radom, Poland

E-mail: d.kotnarowska@pr.radom.pl

(Received 11 September 2011; accepted 4 December 2011)

Abstract. The paper presents investigation results of the effect of epoxy and polyurethane coating modification with three kinds of nanofillers on the resistance to erosive wear. Particles of granulated alundum of grain size 0,6-0,7 mm were used as the abrasive material. They fall freely from the height of 0,94 m and impact the coating surface at an angle of 45°. All polyurethane coatings modified with nanofillers showed higher resistance to erosive wear than the unmodified coatings, regardless of the applied nanofiller. However, the nanofiller modified epoxy coatings showed lower resistance to erosive wear than the unmodified ones.

Keywords: epoxy coating, polyurethane coating, resistance to erosive wear.

1. Introduction

Erosive wear occurs when hard particles impact with high energy the surface of an object. The particles cause wear of the surface what leads to material loses in the superficial layer. The erosive wear is a complex process which consists of several simultaneous and interactive processes proceeding in constant or variable conditions. This wear results, first of all, from plastic deformation and material fatigue.

J. G. A. Bitter and I. Finnie were one of the first who made an attempt [7, 8] to explain the mechanism of erosive wear process. J. G. A. Bitter [9] has defined the erosive wear of an object caused by particles carried away with moving fluid and impacting the surface at high speed ($V > 10$ m/s). This kind of erosive wear is typical for surface coatings applied to protect construction, agricultural, mining and transport facilities. H. C. Meng has described various erosion kinds, for instance – shear erosion and deformation [10]. N. M. Barkoula and I. Finnie [11, 12] made an attempt to systematize definitions and conceptions regarding erosion processes.

In the past, most investigation on erosive wear kinetics concerned mainly metals. Nowadays, apart from traditional materials, polymer composites are commonly applied, among others – to produce protective coatings. Such coatings effectively protect surfaces of machines from the action of exploitation factors, among others – erosive particles.

In many cases, the presence of nanofillers in the coating formulation favourably affects physico-chemical properties of polymeric coatings increasing their durability. Modification with nanofillers of the paint formulation may also extend the period of operation due to lower exothermic effect of the crosslinking reaction. However, it is necessary to choose a proper filler, with proper particle dimensions (fibre length) and its contribution in the composite. The resistance to erosive wear (and also scratch resistance and hardness) may be improved by the addition of, for instance: metal particles, organic clays and metal oxides (ZnO, Al₂O₃) [13-17]. One of the mostly used nanofillers that increases coating resistance to erosive wear is silica [18-20]. Because the surface of most inorganic nanoparticles has hydrophilic character it must be chemically modified (usually with organosilanes) to render it hydrophobic and thereby promote physical bonding with polymer as well as make easier their distribution in the matrix. Surface

treated nanosilica is very good filler in the cases when a coating should be durable and transparent, e.g. automotive finishes.

The need to investigate kinetics of organic coating erosive wear caused by hard particles impacting results from the fact that the process of erosive wear is not sufficiently recognised. This is due to the great complexity of the process of coating erosion. Thermal, physical and chemical phenomena should be taken into consideration. Many factors affect this process. They are, among others: structure of the material which undergoes erosion and its physico-chemical properties as well as the kind of erosive particles, their geometrical parameters, impact angle and velocity.

2. Investigation on the resistance to erosive wear

2. 1. Preparation of test samples

There were investigated three-layer epoxy (EP) and polyurethane (PUR) coatings. Coatings were applied, by air-spraying, on a steel substrate. Two primer layers were epoxy and the surface layer was epoxy or polyurethane. Cross-section schemes of the investigated coating systems are presented in Fig. 1.

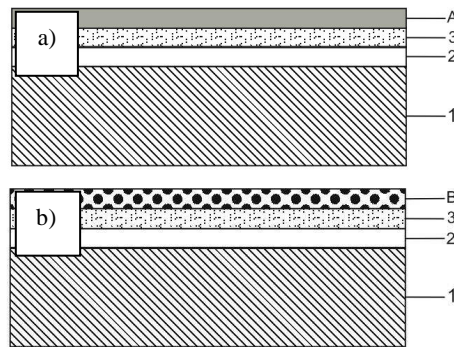

Fig. 1. Cross-section schemes of the investigated polymeric coatings (epoxy – EP, polyurethane – PUR): a) unmodified coating, b) modified coating, 1 – steel substrate; 2 – primer layer I (epoxide); 3 – primer layer II (epoxide); A – unmodified surface layer (EP or PUR), B – modified surface layer (EP or PUR)

In the case of modified coatings, both the epoxy and polyurethane, the paint contained nanofiller in the form of alumina or silica nanoparticles in order to improve their mechanical properties, among others – erosive wear resistance. The nanofiller content was 3,5 wt %. Good blending of agglomerates required long time stirring. In this case, paints were stirred for 18 hours. The applied nanofillers are presented in Table 1. Surfaces of nanofiller particles were chemically modified by manufacturers.

The surfaces of steel (S235JR) samples with dimensions of 170 x 90 x 1,5 mm were prepared by grit blasting (in a special tumbler). Then, the samples were degreased before coating application. The obtained coatings were acclimatised for 10 days at the temperature of 20°C and the relative humidity of 65±5%.

The coating thickness was measured with the use of Mega-Check FE meter (according to the Polish standard PN-EN ISO 2808:2000). The average thickness of three-layer epoxy and polyurethane coatings was 175 µm (EP) and 190 µm (PUR). The surface layer thickness was 55 µm (EP) and 70 µm (PUR) respectively.

Table 1. Characteristics of nanofillers applied for modification of epoxy and polyurethane surface layers

No.	Nanofiller	Symbol	Grain size nm	Content wt %	Kind of the polymeric aperture
1.	Alumina nanoparticles	20-Al ₂ O ₃	20	3.5	surface modified with polysiloxane
2.	Silica nanoparticles	20-SiO ₂	20	3.5	surface modified with polysiloxane
3.	Silica nanoparticles	16-SiO ₂	16	3.5	surface modified with dimethyldichlorosilane

The coating hardness was determined with the application of the Buchholz method (according to the Polish standard PN-EN ISO 2815:2004). For coating roughness measurements the Hommel T500 tester was applied (according to the Polish standards PN-87/M-042251, PN-ISO 8501-1:1996, PN-ISO 8501-1:1998). Properties of epoxy and polyurethane coatings (unmodified and modified) are presented in Table 2.

Table 2. Properties of unmodified and modified epoxy and polyurethane coatings

No.	Coating	Buchholz hardness, H	Parameter Ra, [µm]
1.	EP	85	0,63
2.	EP / 20-Al ₂ O ₃	85	0,52
3.	EP / 20-SiO ₂	86	0,78
4.	EP / 12-SiO ₂	85	0,99
5.	PUR	88	0,30
6.	PUR / 20-Al ₂ O ₃	90	0,22
7.	PUR// 20-SiO ₂	91	0,52
8.	PUR / 12-SiO ₂	89	0,55

2. 2. Erosive wear evaluation methodology

The resistance to erosive wear was tested using the falling of abrasive particles method which consists in subjecting coatings to the action of abrasive material stream. The investigation on erosive wear was carried out using an apparatus recommended by the Polish Standard PN-76/C-81516 (Fig. 2).

The resistance to erosive wear of polymeric coatings was estimated applying a criterion *S* that expresses a proportion of the total mass *M* of erosive particles which erode the coating (exposing the steel substrate surface of the ellipsoid shape with the minor diameter $d = 3,6 \pm 0,1$ mm) to the coating thickness *G*.

$$S = \frac{M}{G}, \tag{1}$$

where: *S* – resistance to erosive wear, [kg/µm];

M – mass of erosive particles, [kg];

G – average coating thickness, [µm].

Particles of granulated alundum 99A (according to the Polish Standard PN-76/M-59111) of grain number 30 (according to PN-ISO 8486-2) were used as the abrasive material. Alundum grains were of the size 0,6-0,7 mm. The main constituent of erosive material was aluminium oxide (minimum 99 %). Other constituents were: silicon dioxide, iron oxide, calcium oxide and

sodium oxide.

A sample with the tested coating was inclined by 45° . The tests were carried out at the temperature of $20 \pm 2^\circ\text{C}$ and the relative humidity of $65 \pm 5\%$.

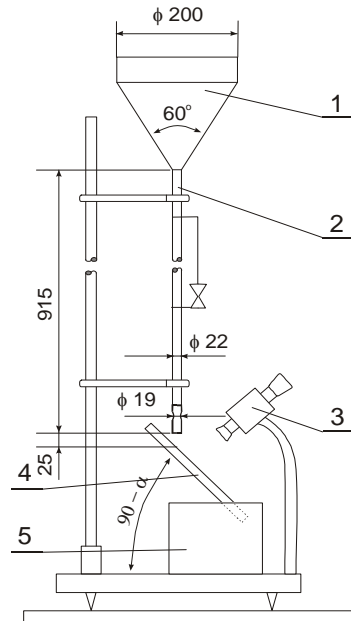

Fig. 2. Apparatus for erosive wear of polymeric coatings testing: 1 - container for erosive material; 2 - pipe transporting erosive material; 3 - optical microscope; 4 - tilting holder for fixing metallic test specimen with examined coating; 5 - container collecting erosive material after the test

3. Investigation results

Results obtained from the investigation on polyurethane and epoxy coatings (subjected to natural weathering for 2 years) allow to state that the modification significantly affects an increase of the resistance to erosive wear of polyurethane coatings. The obtained values describing the resistance to erosive wear of three-layer epoxy (EP) and polyurethane (PUR) coatings (unmodified and modified) and their surface layers (unmodified and modified) are presented in Tables 3 and 4.

Figure 2 presents calculated values of the resistance to erosive wear S of epoxy and polyurethane coatings (unmodified and modified) and their surface layers.

Table 3. The resistance to erosive wear of three-layer epoxy and polyurethane coatings (unmodified and modified)

No.	Coating	Symbol of the nanofiller grain	Resistance to erosive wear S [kg/ μm]	
			EP	PUR
1.	Unmodified coating	----	0,89	0,61
2.	Coating modified with alumina	20- Al_2O_3	0,88	0,65
3.	Coating modified with silica	20- SiO_2	0,81	0,68
4.	Coating modified with silica	16- SiO_2	0,77	0,70

Table 4. The resistance to erosive wear of surface layers of epoxy and polyurethane coatings (unmodified and modified)

No.	Kind of the surface layer	Symbol of the nanofiller grain	Resistance to erosive wear S [kg/ μ m]	
			EP	PUR
1.	Unmodified coating	----	0,59	0,41
2.	Coating modified with alumina	20- Al_2O_3	0,54	0,49
3.	Coating modified with silica	20- SiO_2	0,51	0,57
4.	Coating modified with silica	16- SiO_2	0,50	0,84

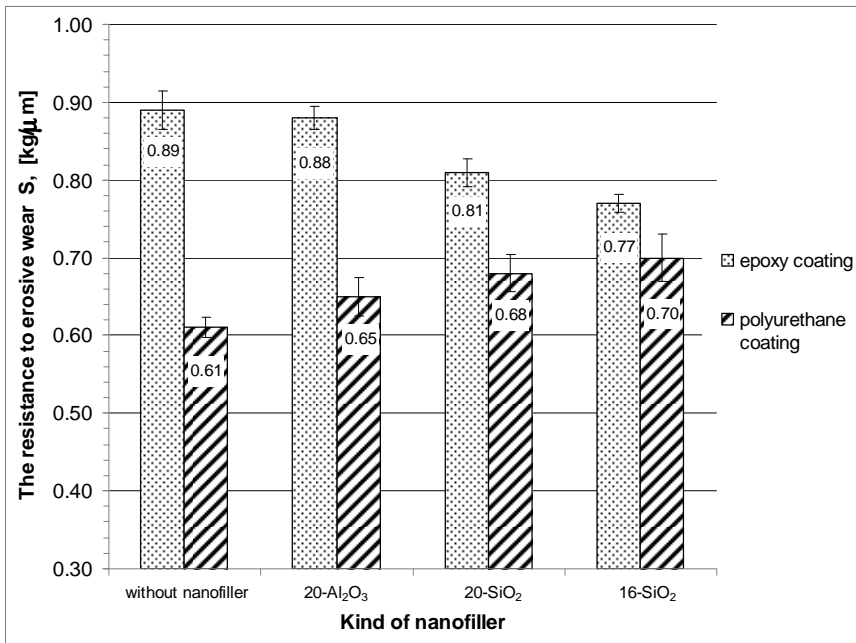

Fig. 3. The resistance to erosive wear of epoxy and polyurethane coatings (unmodified and modified)

4. Conclusions

1. Results obtained from the carried out investigation allow to state that the modification with nanofiller of polyurethane coating formulation favourably affects an increase of the resistance to erosive wear of polyurethane coatings.
2. Kind of nanofiller and its size (in the case of silica) significantly affected an increase of the resistance to erosive wear of polyurethane coatings. The highest resistance to the action of erosive particles was obtained in the case of modification with silica of the polyurethane surface layer. Moreover, it was observed that the smaller the filler grain the higher the resistance to erosive wear.
3. However, lower resistance to erosive wear was observed for modified epoxy coatings in comparison with the unmodified ones. For instance, in the case of modification with silica (with grain diameter equal to 16 nm) the resistance decrease was the highest (on average by 13%).
4. It results from the above that the universal nanofillers do not exist and each of the investigated polymeric coating formulations should be optimized in consideration of the kind and size of nanofiller in order to obtain higher resistance to erosive wear.

References

- [1] **Kotnarowska D.** Kinetics of wear of epoxide coating modified with glass microspheres and exposed to the impact of alundum particles. *Progress in Organic Coatings*, Vol. 31, 1997, p. 325-330.
- [2] **Kotnarowska D.** Epoxy coating destruction as a result of sulphuric acid aqueous solution action. *Progress in Organic Coatings*, Vol. 67, Issue 3, 2010, p. 324-329.
- [3] **Kotnarowska D.** Influence of ultraviolet radiation and aggressive media on epoxy coating degradation. *Progress in Organic Coatings*, Vol. 37, 1999, p. 149-159.
- [4] **Kotnarowska D.** Influence of mechanical factors on surface state of acrylic coatings with nanofillers. *Material Science*, Vol. 14, Issue 4, 2008, p. 283 – 287.
- [5] **Kotnarowska D.** Effect of nanofillers on wear resistance of polymer coatings. *Solid State Phenomena*, Vol. 144, 2009, p. 285-290.
- [6] **Kotnarowska D.** Erosion of polymer coatings. Monograph, Publishing House of Technical University of Radom, 2009, (in Polish), 144 p.
- [7] **Bitter J. G. A.** A study of erosion phenomena. Part I, *Wear*, Vol. 6, 1963, p. 5-21.
- [8] **Finnie I.** Erosion of surfaces by solid particles, *Wear*, Vol. 3, 1960, p. 87-103.
- [9] **Bitter J. G. A.** A study of erosion phenomena. Part II, *Wear*, Vol. 6, 1963, p. 169-190.
- [10] **Meng H. C., Ludema K. C.** Wear models and predictive equations: their form and content. *Wear*, 1995, p. 181-183.
- [11] **Barkoula N.-M.** Review processes and influencing parameters of the solid particle erosion of polymers and their composites, *Journal of Materials Science*, Vol. 37, 2002.
- [12] **Finnie I.** Some reflections on the past and future of erosion, *Wear*, Vol. 186/187, 1995, p. 1-10.
- [13] **Li J. H., Honga R. Y., et al.** Effects of ZnO nanoparticles on the mechanical and antibacterial properties of polyurethane coatings, *Progress in Organic Coatings*, Vol. 64, 2009, p. 504-509.
- [14] **Yusoh Y., Jin J., Song M.** Subsurface mechanical properties of polyurethane / organoclay nanocomposite thin films studied by nanoindentation, *Progress in Organic Coatings*, 67, 2010.
- [15] **Zhou R., Lu D. H., Jiang Y. H., Li Q. N.** Mechanical properties and erosion wear resistance of polyurethane matrix composites, *Wear*, Vol. 259, 2005, p. 676-683.
- [16] **Sabzi M., Mirabedini S. M., Zohuriaan-Mehr J., Atai M.** Surface modification of TiO₂ nanoparticles with silane coupling agent and investigation of its effect on the properties of polyurethane composite coating, *Progress in Organic Coatings*, Vol. 65, 2009, p. 222-228.
- [17] **Wang Y., Lim S., Luo J. L., Xu Z. H.** Tribological and corrosion behaviours of Al₂O₃ / polimer nanocomposite coatings, *Wear*, Vol. 260, 2006, p. 976-983.
- [18] **Leder G., Ladwig T., Valter V., Frahn S., Meyer J.** New effects of fumed silica in modern coatings. *Progress in Organic Coatings*, Vol. 45, 2002, p. 139-144.
- [19] **Zhou S., Wu L., Sun J., Shen W.** The change of the properties of acrylic-based polyurethane via addition of nano-silica. *Progress in Organic Coatings*, Vol. 45, 2002, p. 33-42.
- [20] **Amerio E., Fabbri P., Malucelli G., Messori M., Sangermano M. Taurino R.** Scratch resistance of nano-silica reinforced acrylic coatings. *Progress in Organic Coatings*, Vol. 62, 2008, p. 129-133.